



**Hewlett Packard
Enterprise**

PROPOSALS MASTERS WEBFORUM

Encuentro mensual Técnico-Comercial/Operativo

26 de Mayo, 2023

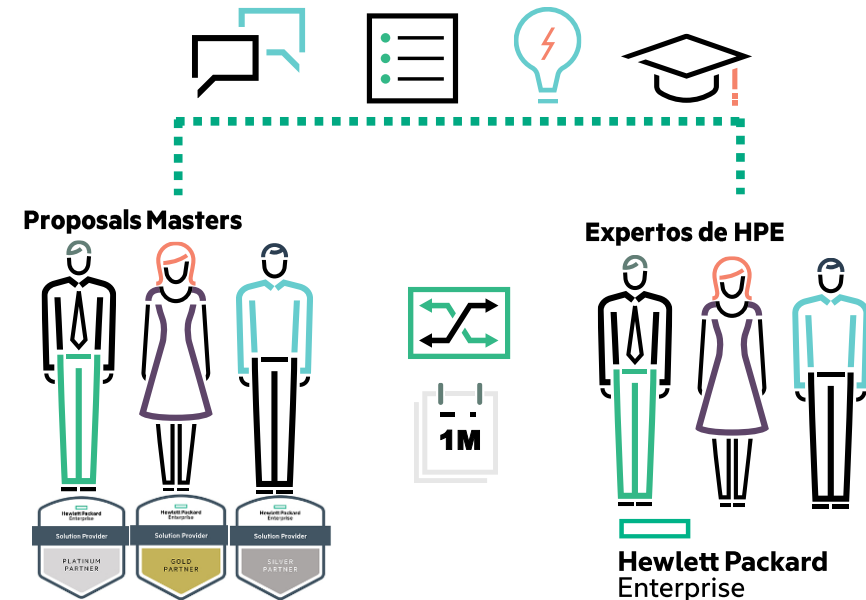

AGENDA DE 26 DE MAYO 2023

“ZERTO 10 Y SYNERGY GEN 11, ENTRE OTROS”

Intro	10:00 – 10:05	Introducción	Jaime Garrido, HPE Customer Operations
I	10:05 – 10:10	Resetear contraseña Partner Ready Portal	
	10:10 – 10:15	Estado del Partner en Partner Ready Portal	
II	10:15 – 10:25	Zerto 10	Alvaro Casado, Consultor Preventa HPE, Pleiades
III	10:25 – 10:30	Packaged Support Services de larga duración	Juan Antonio Anierte HPE CSLV
IV	10:30 – 10:40	Actualización Synergy Gen 11	Juanan Ibañez, Consultor Preventa HPE, Pleiades
V	10:40 – 10:50	Servicios a medida	Goyo Fernandez HPE CSLV
Final	10:50 – 10:55	“Call to Action” + Preguntas y Respuestas	Jaime Garrido, HPE Customer Operations

PROPOSALS MASTERS WEBFORUM

Fórum mensual “Técnico-Comercial” + “Operativo”

Partner's Proposals Masters

- Ventas
- Soporte Comercial

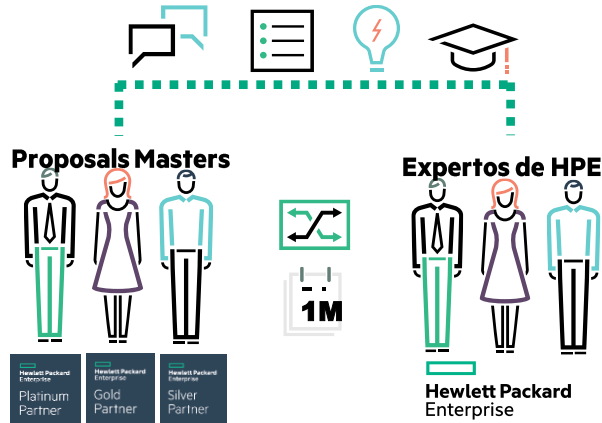

Expertos de HPE

- Ventas
- TechHub
- BU's: Hybrid IT, Pointnext
- Operaciones de Ventas



Opportunities Pipeline Management



1. Learning & Certification



2. Customer Presales Activities



3. Deal Registration (optional)

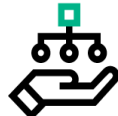

4. System Sizing & Design

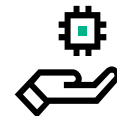

5. System & Services Configuration



6. Pricing Quote



7. TCO/ROI Analysis (optional)



8. Customer Solution Proposal



Compendiums & Master Info

¿HA SIDO ESTA SESIÓN ÚTIL PARA TI?

Feedback de los Partners: 100% MUY ÚTIL o ÚTIL

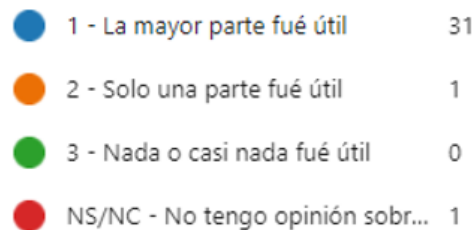

94%

(31) la encontraron **MUY ÚTIL**

No se considera el NS/NC

AGENDA DE 5 MAYO 2023 “ALMACENAMIENTO Y GREENLAKE”

Intro	10:00 – 10:05	Introducción	Jaime Garrido, HPE Customer Operations
I	10:05 – 10:15	Recordatorio Certificaciones comerciales y Master ASE	
II	10:15 – 10:25	Herramienta CAP	Juan Antonio Anierte HPE CSLV
III	10:25 – 10:50	Almacenamiento y GreenLake	Jorge Martin, Consultor Preventa HPE, Pleiades
IV	10:50 – 11:00	HPE Education: Ayuda a tus clientes en la Transformación Digital	Jaime Hortas, HPE Education
V	11:00 – 11:05	Better Together Portal AMD/HPE	Sofía Bonilla HPE Alliances
Final	11:05 – 11:10	“Call to Action” + Preguntas y Respuestas	Jaime Garrido, HPE Customer Operations

PROPOSAL MASTER WEBFORUM

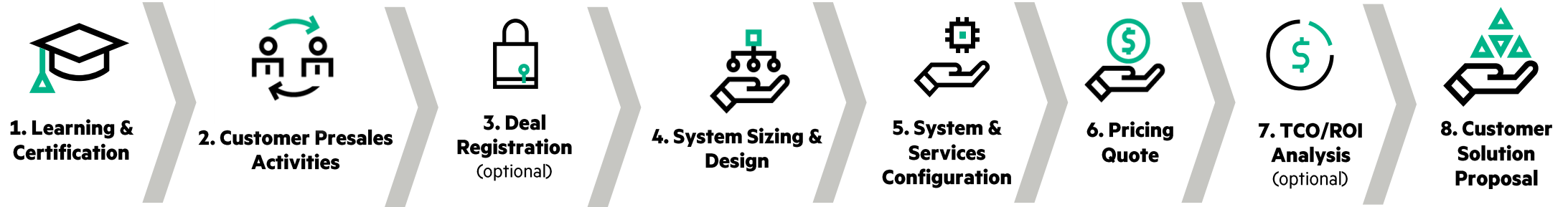

Objetivo	No-Objetivo	Se complementa con
<ul style="list-style-type: none"> – Visión global de los recursos disponibles – Información sobre actualizaciones en procesos y herramientas – Repaso de las prácticas más habituales 	<ul style="list-style-type: none"> – No es formación detallada ni de las actividades ni de las herramientas 	<ul style="list-style-type: none"> – Guías y tutoriales disponibles en el Partner Ready Portal – Webinars accesibles en el Partner Ready Portal

AGENDA DE 26 DE MAYO 2023

“ZERTO 10 Y SYNERGY GEN 11, ENTRE OTROS”



Intro	10:00 – 10:05	Introducción	Jaime Garrido, HPE Customer Operations
I	10:05 – 10:10	Resetear contraseña Partner Ready Portal	
	10:10 – 10:15	Estado del Partner en Partner Ready Portal	
II	10:15 – 10:25	Zerto 10	Alvaro Casado, Consultor Preventa HPE, Pleiades
III	10:25 – 10:30	Packaged Support Services de larga duración	Juan Antonio Anierte HPE CSLV
IV	10:30 – 10:40	Actualización Synergy Gen 11	Juanan Ibañez, Consultor Preventa HPE, Pleiades
V	10:40 – 10:50	Servicios a medida	Goyo Fernandez HPE CSLV
Final	10:50 – 10:55	“Call to Action” + Preguntas y Respuestas	Jaime Garrido, HPE Customer Operations

RESETEAR CONTRASEÑA PRP

Pasos

PASO 1

A través de navegador Chrome, copia el siguiente [link](#) y elimina todas las cookies



HPE Partner Ready Portal

Passport sign in

Language	English
Email	firstname.lastname@company.com
Password	Secure password

Save sign in

[Forgot Password?](#)

Sign in

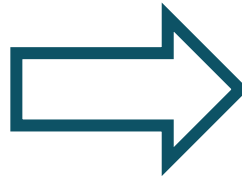

PASO 2



Forgot password

If you don't remember your HPE Passport password, you can create a new one.

Required *

Email address *

Next

HPE Passport is secure [?](#)

Don't have an account? [Create one](#)

[Sign-in with HPE Passport](#)
[New User Registration](#)
[Forgot User ID](#)
[Forgot Password](#)
[Change Email ID](#)
[About HPE Passport](#)

RESETEAR CONTRASEÑA PRP

Pasos

PASO 3

Forgot password

If you don't remember your HPE Passport password, you can create a new one.

1 Verify email > 2 Answer security questions > 3 Change Password

Required *

User ID
MAPDUMMYPARTNER@YOPMAIL.COM

Security question 1
Where was your first job? (full name of city only)

Security answer 1 *

Security question 2
What is the company name of your first employer?

Security answer 2 *

Send me an email

Next

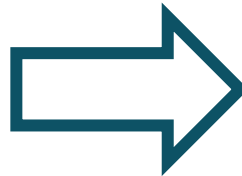

PASO 4

ABRIR el link que nos han enviado través de navegador Chrome y generar nueva contraseña

Hewlett Packard
Enterprise

Solutions

Services

Products

About Us

Support

Forgot password

If you don't remember your HPE Passport password, you can create a new one.

Required *

User ID
DEMO_FRENCH_DISTRI@YOPMAIL.COM

New password * ?

Confirm password *

Sign in

HPE Passport is secure ?

Don't have an account? [Create one](#)

RESETEAR CONTRASEÑA PRP

Pasos

PASO 5

Una vez tenemos la confirmación, volvemos a Partner Ready Portal y entramos con la contraseña

 Hewlett Packard
Enterprise

[Solutions](#)

[Services](#)

[Products](#)

[About Us](#)

[Support](#)

Welcome, DEMO_FRENCH_DISTRI@YOPMAIL.COM

Reset HPE Passport Password

Your new password has been established. Use this new password next time you sign-in to HPE Passport.

[Edit your profile](#)
[Change User ID](#)
[Change Password](#)
[Change Security Q&A](#)
[Delete Profile](#)
[Sign-out](#)
[About HPE Passport](#)

[Continue to site](#)

HPE PARTNER READY PROGRAM READINESS

Estado del Partner

✕ HPE Partner Ready Portal

- Inicio
- Productos, Servicios y Soluciones
- HPE Partner Ready Vantage
- HPE Partner Ready**
- Herramientas
- Certification & Enablement
- Ventas y Marketing

- HPE Partner Ready
- Membresía**
- Solution Provider
- Services Partner
- Delivery
- HPE Partner Ready for Aruba

Membresía

Realiza el seguimiento de tu estado de membresía, descarga insignias y certificados, y aprovecha al máximo las ventajas a tu disposición.

- Estado del Partner**
- Competencias
- Documentos Esenciales
- Ofertas y Servicios

HPE Partner Ready Membership Status



FY23 Membership	FY24 Potential Membership	Competencias
Especializaciones actuales	Especializaciones siguiente FY con consecución actual	FY23 Competencias FY23 2
		FY24 Competencias para Readiness FY24 1

Partner Status

FY23 Membership upgrades | FY24 Membership readiness | Certificates

- HPE Partner Ready Membership
- HPE Partner Ready Competencies
- HPE Partner Ready for Aruba: Networking Membership
- HPE Partner Ready for Aruba: Networking Competencies

1. **FY23 Membership upgrades tab:** Threshold performance measured on last completed rolling 12 months net \$ sellout incl. Hybrid Cloud product line multipliers (not applicable for HPE Business Partner).
 2. **FY24 Membership readiness tab:** Threshold performance measured on 1-Oct-2022 to 30-Sep-2023 net \$ sellout incl. Hybrid Cloud product line multipliers (not applicable for HPE Business Partner).

Partner details

Resumen del estado del Partner y IDs



HPE Partner Ready Insignia

Solution Provider - Platinum - Citrix and VMware Horizon on HPE



DOWNLOAD

HPE PARTNER READY PROGRAM READINESS

Competencias

✕ HPE Partner Ready Portal

- Inicio
- Productos, Servicios y Soluciones
- HPE Partner Ready Vantage
- HPE Partner Ready**
- Herramientas
- Certification & Enablement
- Ventas y Marketing

- HPE Partner Ready
- Membresía**
- Solution Provider
- Services Partner
- Delivery
- HPE Partner Ready for Aruba



Membresía

Realiza el seguimiento de tu estado de membresía, descarga insignias y certificados, y aprovecha al máximo las ventajas a tu disposición.

- Estado del Partner**
- Competencias
- Documentos Esenciales
- Oferas y Servicios



HPE Partner Ready Competencies

Competencies

Choose from the list below to learn more about each solution. Each competency contains step-by-step instructions and resources.

- Microsoft on HPE**
Microsoft on HPE partners function as trusted advisors to help their customers analyze and provision the right mix of services in cloud and on premises to run their businesses. [Learn more](#)
- VMware on HPE**
VMware on HPE partners help their customers analyze and provision the right mix of services in cloud and on premises to run their businesses. [Learn more](#)
- Containers on HPE**
These partners function as trusted advisors to help customers consolidate, modernize, and automate their IT infrastructure to eliminate manual processes, and increase the speed to deployment and flexibility of IT service delivery. [Learn more](#)

Topics

- Hybrid Cloud

Resources

- Mobile field guide
- Competencies FAQs
- Competencies brochure

How to earn a competency

Step 1: Validate your skills

Optional: preparation course: [Creating HPE Microsoft Solutions, Rev. 21.41](#)
Required: pass the solution exam: [Creating HPE Microsoft Solutions](#)

Step 2: Demonstrate solution experience and skills

Submit one [solution validation](#) for approval

AGENDA DE 26 DE MAYO 2023

“ZERTO 10 Y SYNERGY GEN 11, ENTRE OTROS”



Intro	10:00 – 10:05	Introducción	Jaime Garrido, HPE Customer Operations
I	10:05 – 10:10	Resetear contraseña Partner Ready Portal	
	10:10 – 10:15	Estado del Partner en Partner Ready Portal	
II	10:15 – 10:25	Zerto 10	Alvaro Casado, Consultor Preventa HPE, Pleiades
III	10:25 – 10:30	Packaged Support Services de larga duración	Juan Antonio Anierte HPE CSLV
IV	10:30 – 10:40	Actualización Synergy Gen 11	Juanan Ibañez, Consultor Preventa HPE, Pleiades
V	10:40 – 10:50	Servicios a medida	Goyo Fernandez HPE CSLV
Final	10:50 – 10:55	“Call to Action” + Preguntas y Respuestas	Jaime Garrido, HPE Customer Operations

AGENDA DE 26 DE MAYO 2023

“ZERTO 10 Y SYNERGY GEN 11, ENTRE OTROS”



Intro	10:00 – 10:05	Introducción	Jaime Garrido, HPE Customer Operations
I	10:05 – 10:10	Resetear contraseña Partner Ready Portal	
	10:10 – 10:15	Estado del Partner en Partner Ready Portal	
II	10:15 – 10:25	Zerto 10	Alvaro Casado, Consultor Preventa HPE, Pleiades
III	10:25 – 10:30	Packaged Support Services de larga duración	Juan Antonio Anierte HPE CSLV
IV	10:30 – 10:40	Actualización Synergy Gen 11	Juanan Ibañez, Consultor Preventa HPE, Pleiades
V	10:40 – 10:50	Servicios a medida	Goyo Fernandez HPE CSLV
Final	10:50 – 10:55	“Call to Action” + Preguntas y Respuestas	Jaime Garrido, HPE Customer Operations



ZERTO 10

**REAL-TIME DETECTION
MEETS REAL-TIME
PROTECTION**

Zerto

a Hewlett Packard
Enterprise company



Real-Time
Detection

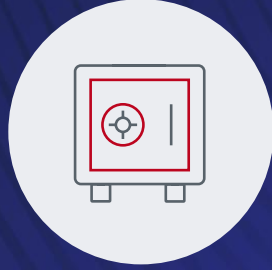

Cyber Resilience
Vault



Secure
Appliance



Protecting Azure
at Scale



LAUNCH
May 18th

GA
June 13th

TOP CUSTOMER CHALLENGES



Ransomware

\$265B estimated cost of ransomware by 2031



Unplanned/Planned Disruptions

62.9% organizations have suffered a disruption



Cloud Complexity

By 2025, **100 zettabytes** of cloud data

Need 24x7: No downtime and no data loss

Top Challenges We Hear From Customers



Evolving Threat Landscape

Last year, 61% of disaster responses were triggered by ransomware



Slow Speed of Recovery

Average time to recover from ransomware is ONE MONTH



Ransomware's Catch-22 Dilemma

Lose data or pay ransom—and only 4% of those who paid got all their data back anyway



Staying in Compliance

GDPR, SOX, HIPAA, Sheltered Harbor, FISMA, NIST, etc

**#1 REPLICATE
AND DETECT**

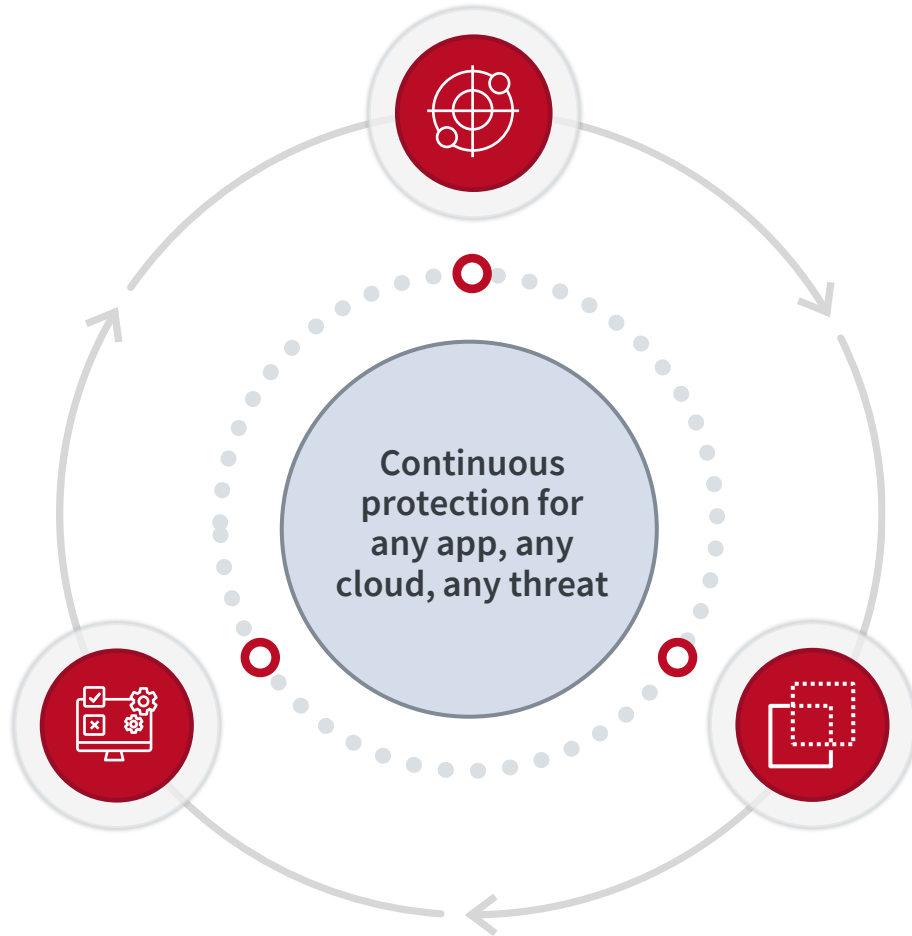

**#2 ISOLATE
AND LOCK**

**#3 TEST AND
RECOVER**

Ransomware Resilience with Zerto



ZERTO 10
Real-time
Detection Meets
Real-time
Protection

REPLICATE AND DETECT

ISOLATE AND LOCK

TEST AND RECOVER

Anatomy of an Attack

Example using revised MITRE ATT&CK framework

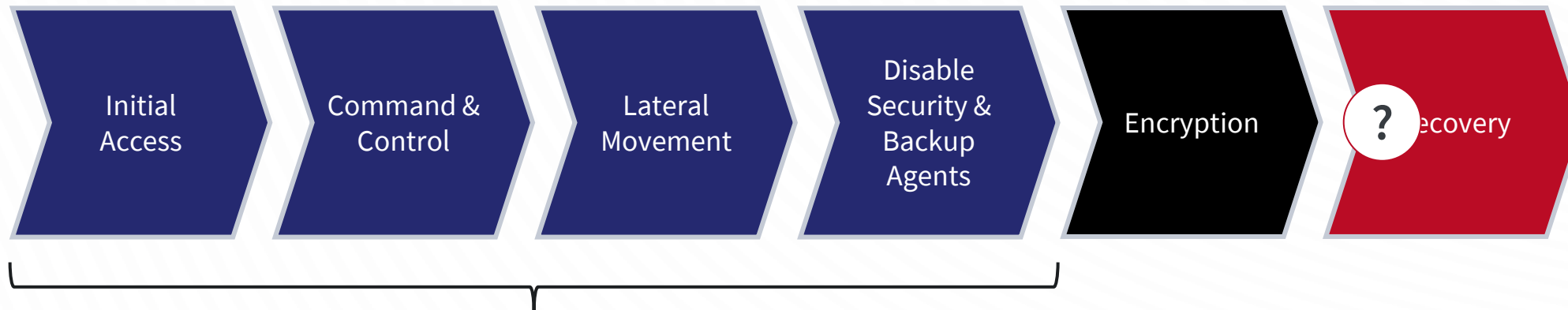

Median dwell time: **5 - 9 days** *

How to detect encryption and know if recovery is needed?

Backup-based Detection is Inadequate

Speed is Critical to Ransomware Resilience

Longer RTO = Larger Ransomware Impact = Higher Cost

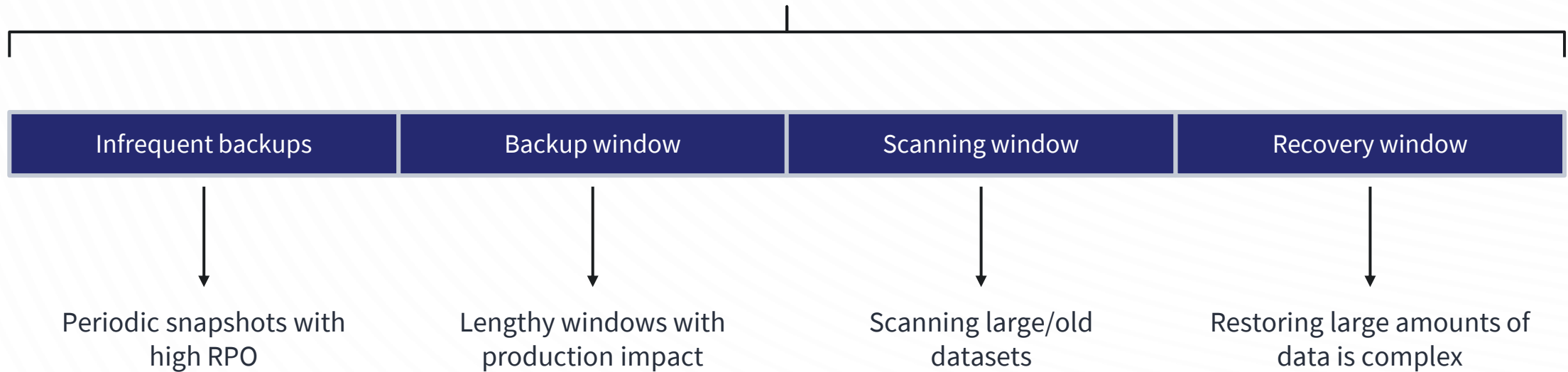

Journal-Based Recovery

Rewind and recover to any point in time

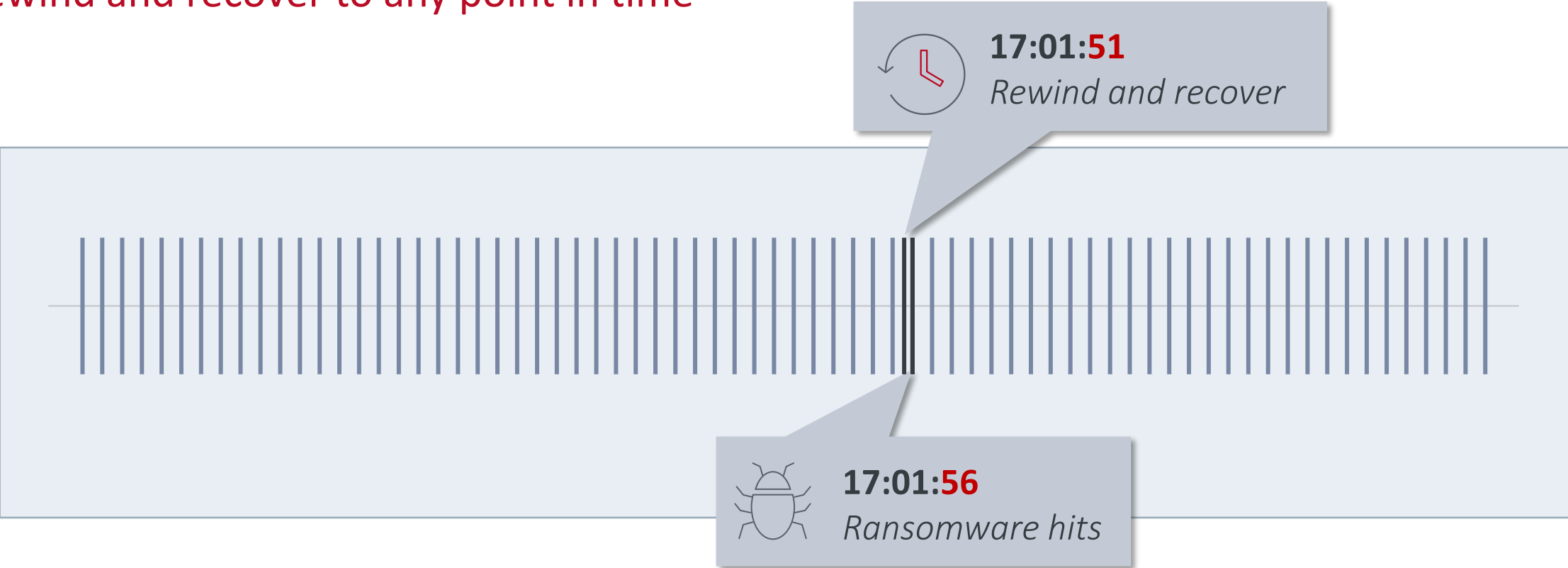

 Sites

 Apps

 VMs

 Files

Earliest
warning when
an attack is
occurring

Detect at the point of encryption, not after backing up

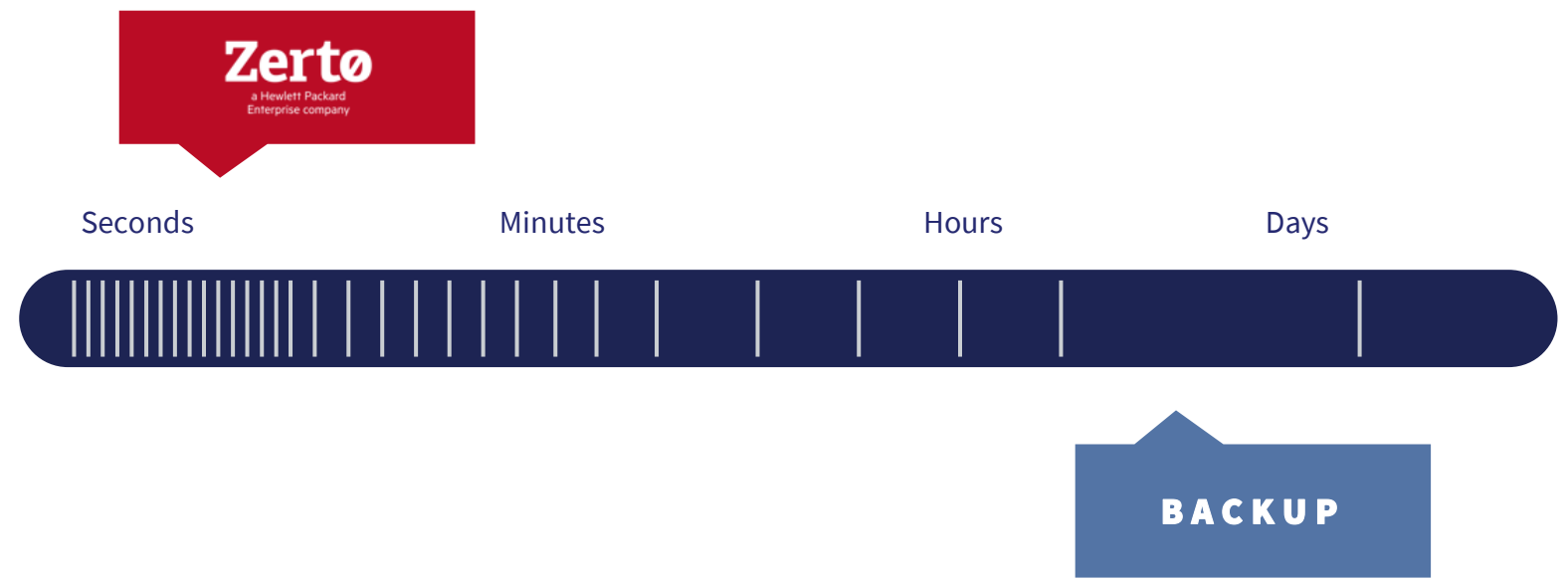

Real-time detection and alerting at the first moment of impact

Easily identify blast radius and tag compromised applications

No additional components required and included at no cost in Zerto 10

Replicate and Detect

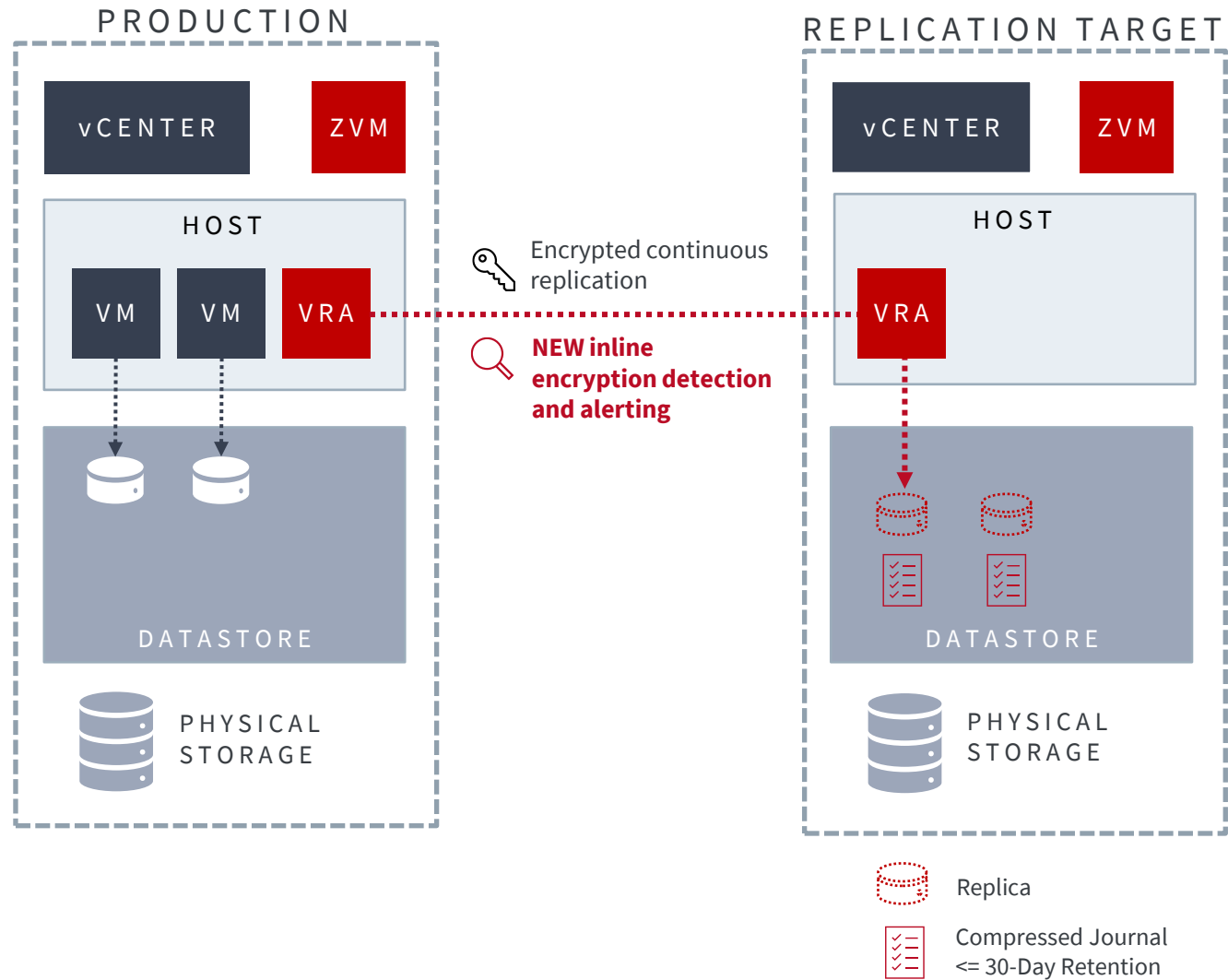

NO additional components or infrastructure required

NO additional cost— included with Zerto 10

Replicate and Detect

Replicate every change and log as recovery checkpoints every 5-15 seconds

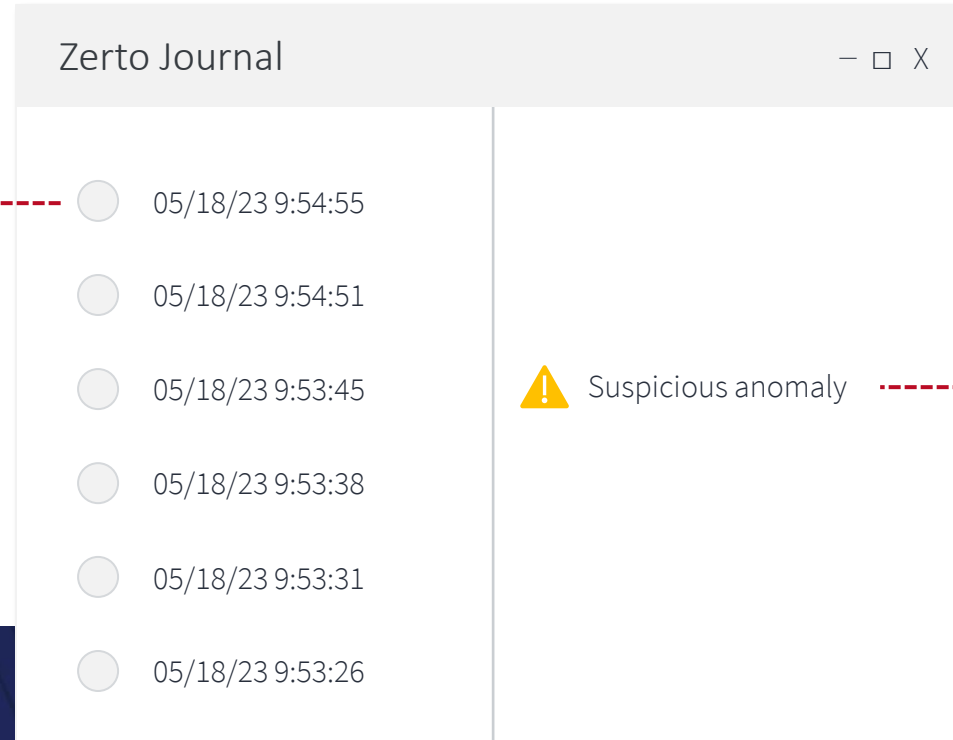

Detect suspicious writes as they stream in and flag for admins to investigate

“[Zerto’s] real-time ransomware detection puts us in a much stronger position to both identify and mitigate ransomware attacks. This gives us confidence that we can proactively meet the risks presented by ransomware.”

– Network admin at manufacturing customer

Replicate and Detect



Real-time: earliest warning of the encryption phase of an attack



Quickly identify blast radius and only recover infected VMs/apps—and do so to a recovery point seconds before the encryption started



Minimize data loss by enabling IT or SecOps to take action mid-attack rather than hours or days after encryption



Integrate with existing cybersecurity solutions—maximize power of the encryption analyzer without being locked into closed system



NO additional infrastructure required, NO impact to production, and included at NO additional cost in Zerto 10



ZERTO 10
Real-time
Detection Meets
Real-time
Protection

REPLICATE AND DETECT
ISOLATE AND LOCK
TEST AND RECOVER

Why a Vault

“Isolated recovery environments (IREs) with immutable data vaults (IDVs) provide the highest level of security and recovery against insider threats, ransomware and other forms of hacking.”

Gartner

Zerto
a Hewlett Packard
Enterprise company

Increasing pressure on organizations



Anatomy of an Attack

Example using revised MITRE ATT&CK framework

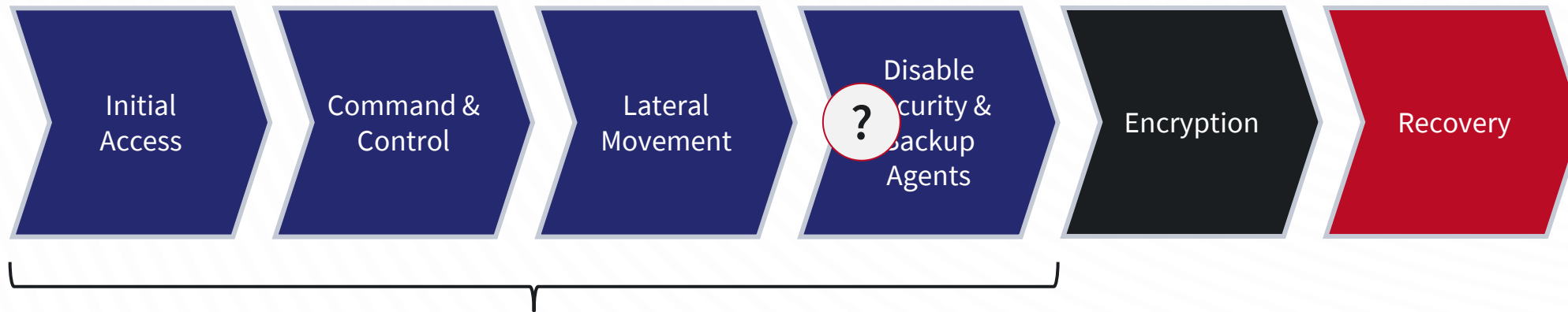

Median dwell time: **5 - 9 days** What are the options in worst case scenario if ransomware has spread widely?

Introducing the Zerto Cyber Resilience Vault

Isolated, offline, and air gapped with immutable data copies using zero trust architecture

Recovery option of last resort in worst case scenarios



- ✓ **ISOLATED**
- ✓ **AIR GAPPED**
- ✓ **IMMUTABLE**
- ✓ **ZERO TRUST**

Zerto Cyber Resilience Vault



Combines an isolated recovery environment, or clean room, with a locked down data vault using unique zero trust architecture.



The vault enables physically air-gapped and immutable data copies on secure, high-performance hardware.



With no centralized control plane, the vault does not have an exposed management port and does not have any single point of compromise.



Meet compliance requirements, including standards based on HIPAA, GDPR, SOX, Sheltered Harbor, or FISMA and NIST

Zerto Cyber Resilience Vault

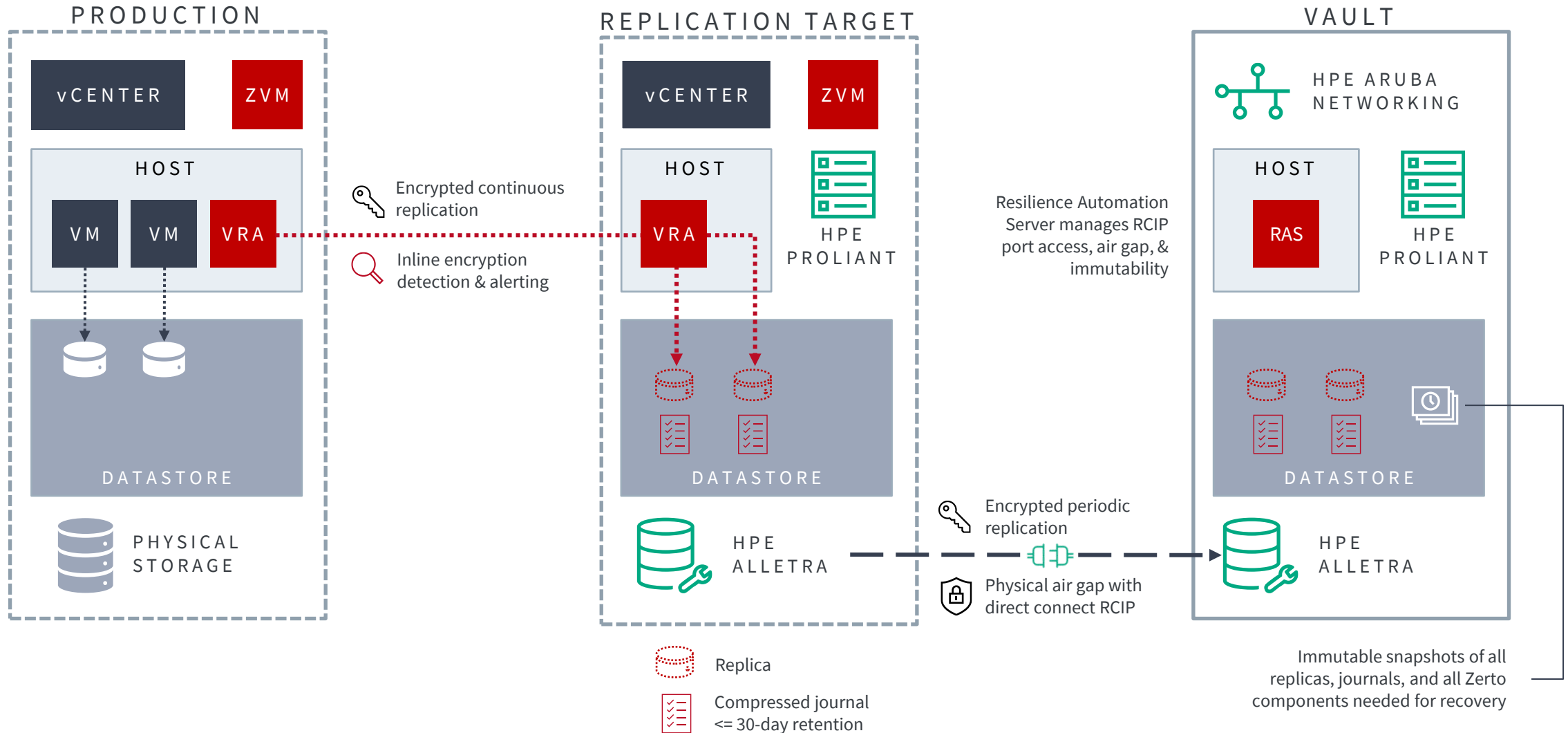



ZERTO 10
Real-time
Detection Meets
Real-time
Protection

REPLICATE AND DETECT
ISOLATE AND LOCK
TEST AND RECOVER

TEST OFTEN, TEST EXTENSIVELY

<p>BEFORE ZERTO</p> <p>3.5 Days</p>	 <p>Insurance Customer</p>	<p>AFTER ZERTO</p> <p><2 Hours</p>
--	---	--

No impact to production

Orchestrated & automated failover tests

Ready-made compliance reporting

Cyber Resilience Vault Architecture - Recovery

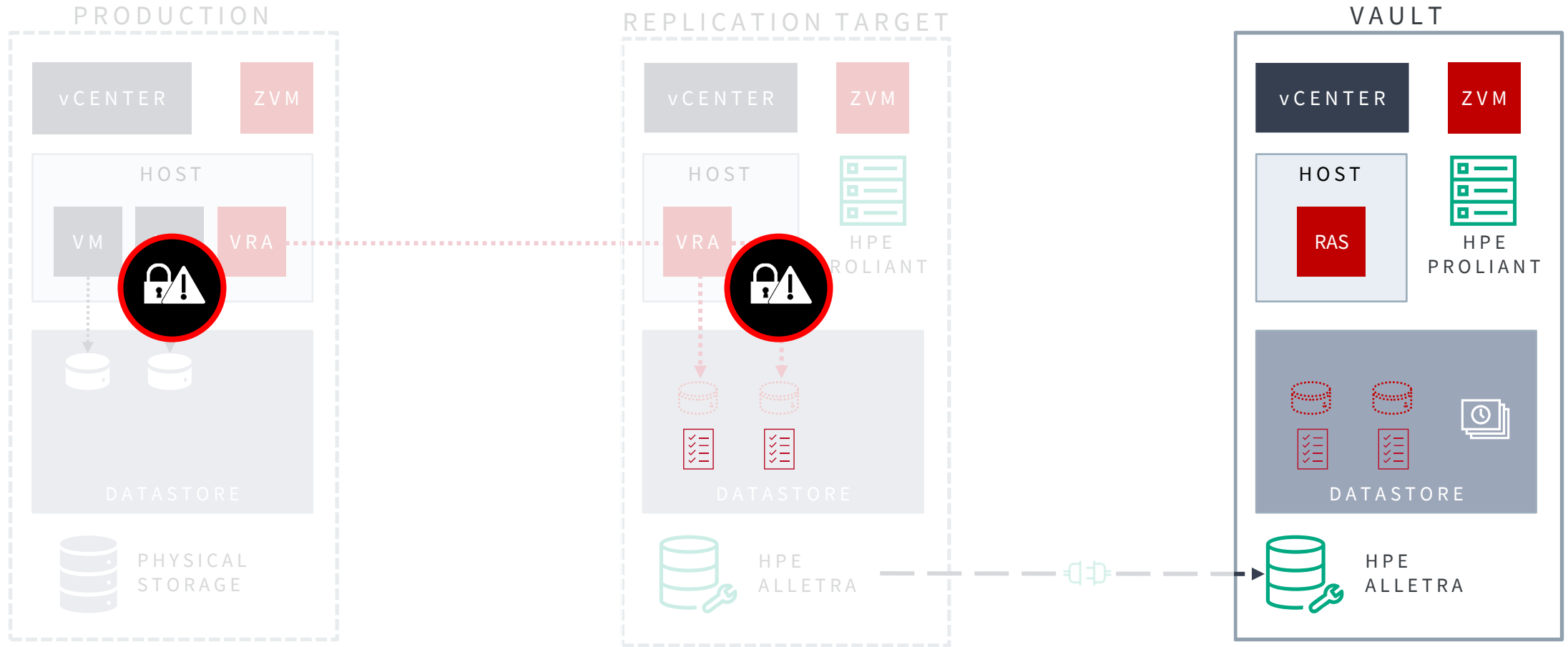

- 1 Select apps or VMs to recover
- 2 Mount VMFS from immutable snapshot
- 2 Select clean checkpoint from journal
- 3 Power on vCenter, ESX, and Zerto VMs
- 3 Non-disruptively test and validate clean restore point
- 3 Recover from Zerto journal
- 4 Recover all infected workloads within minutes

Cyber Resilience Vault ROI

Rapid Recovery Means Less Ransomware Impact

	Leading Backup-Based Cyber Vault *	Zerto <small>a Hewlett Packard Enterprise company</small>	Zerto Benefits
Last Good Copy (RPO)	32 – 56 hours	4 hours	>87% Reduction
Time to Restore (RTO)	16 – 18 days	2 hours	>99% Reduction
Total Ransomware Impact	20+ days	6 hours	>99% Reduction
Journal-Based Recovery	NO	YES	Only journal-based solution for cyber recovery

* Example based on customer protecting 300 VMs and 300 TBs

Test and Recover



Flexible architecture enables multiple options for isolated testing environment and clean rooms

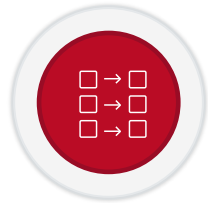

Non-disruptive tests: NO production performance, NO agents, NO impact to ongoing protection



Easily validate clean restore points and quickly rollback to different checkpoint as needed



Rapid recovery using battle-tested orchestration & automation engine, including app-centric and journal-based approach to accelerate RTO

Ransomware Resilience With Zerto

01

REPLICATE AND DETECT

Streaming near-synchronous data replication protects every production write in real-time and immediately alerts on any suspicious anomalies.

02

ISOLATE AND LOCK

Separated vault is physically air-gapped and stores immutable data copies on secure, FIPS-validated hardware.

03

TEST AND RECOVER

Easily identify clean restore points and then quickly recover entire multi-VM apps onto high-performance storage—all while maintaining cross-VM consistency at scale



ZERTO 10
Real-time
Detection Meets
Real-time
Protection



Enhanced and New Protection for Azure

Current Customer Challenges



Enhanced and Expanded Microsoft Azure Integration **at Scale**



NEW

Refactored architecture reduces costs, simplifies management, and increases scalability

NEW

Support for multi-disk consistency leveraging new co-developed Azure APIs

UPDATED

Enhanced support for highly orchestrated DR to, from, and within Azure

Protection To, From, and Within Azure

Disaster Recovery to Azure

Protect data and applications with Azure as a remote DR site with immutable copies

Disaster Recovery within Azure

Orchestrated protection at scale for in-cloud DR across Azure regions

Migration to Azure

Seamlessly move VM workloads to, from, and within Azure

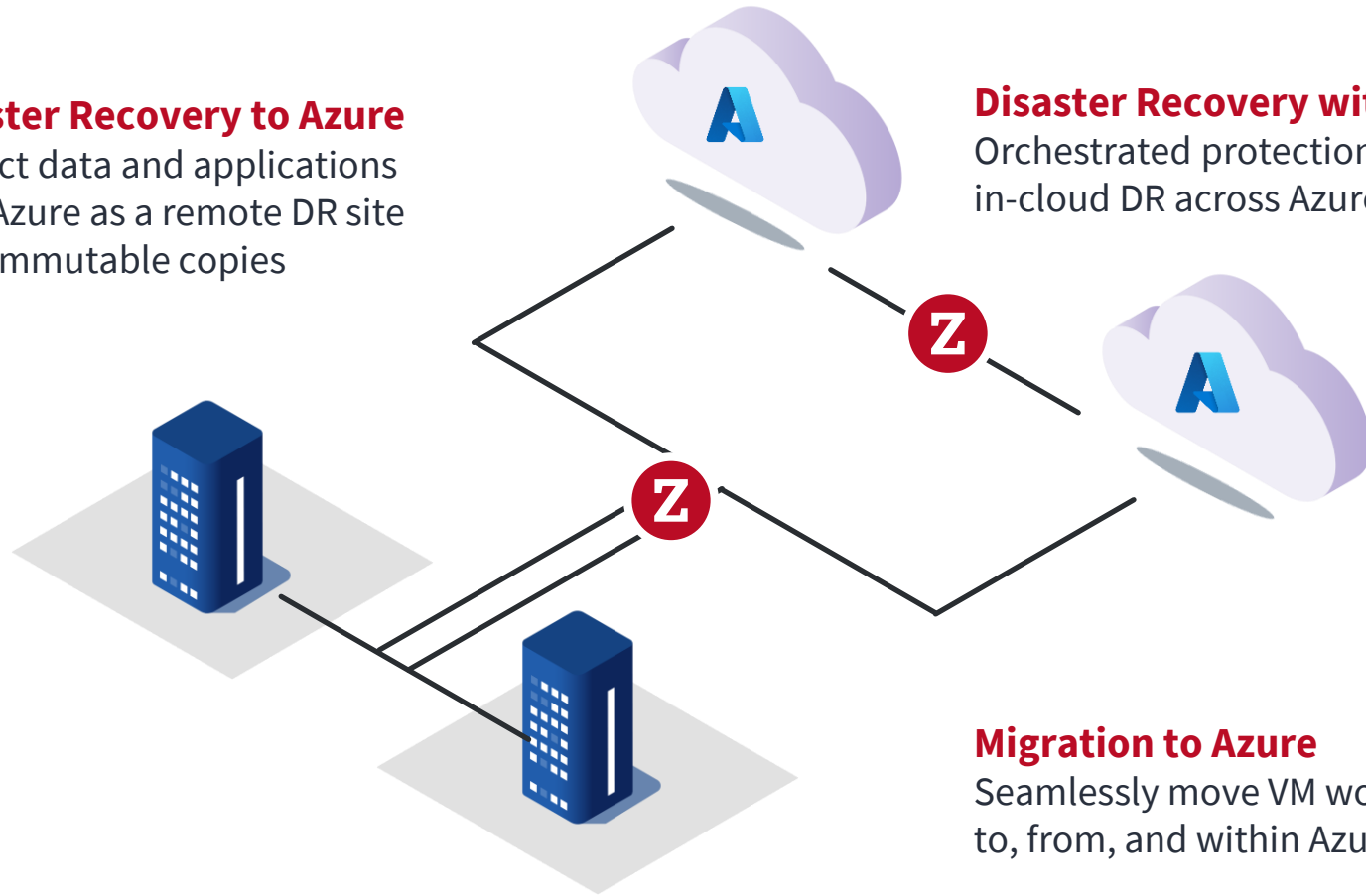

Zerto for Azure Architectures: Hybrid to Cloud

Local Replication and DR to Azure

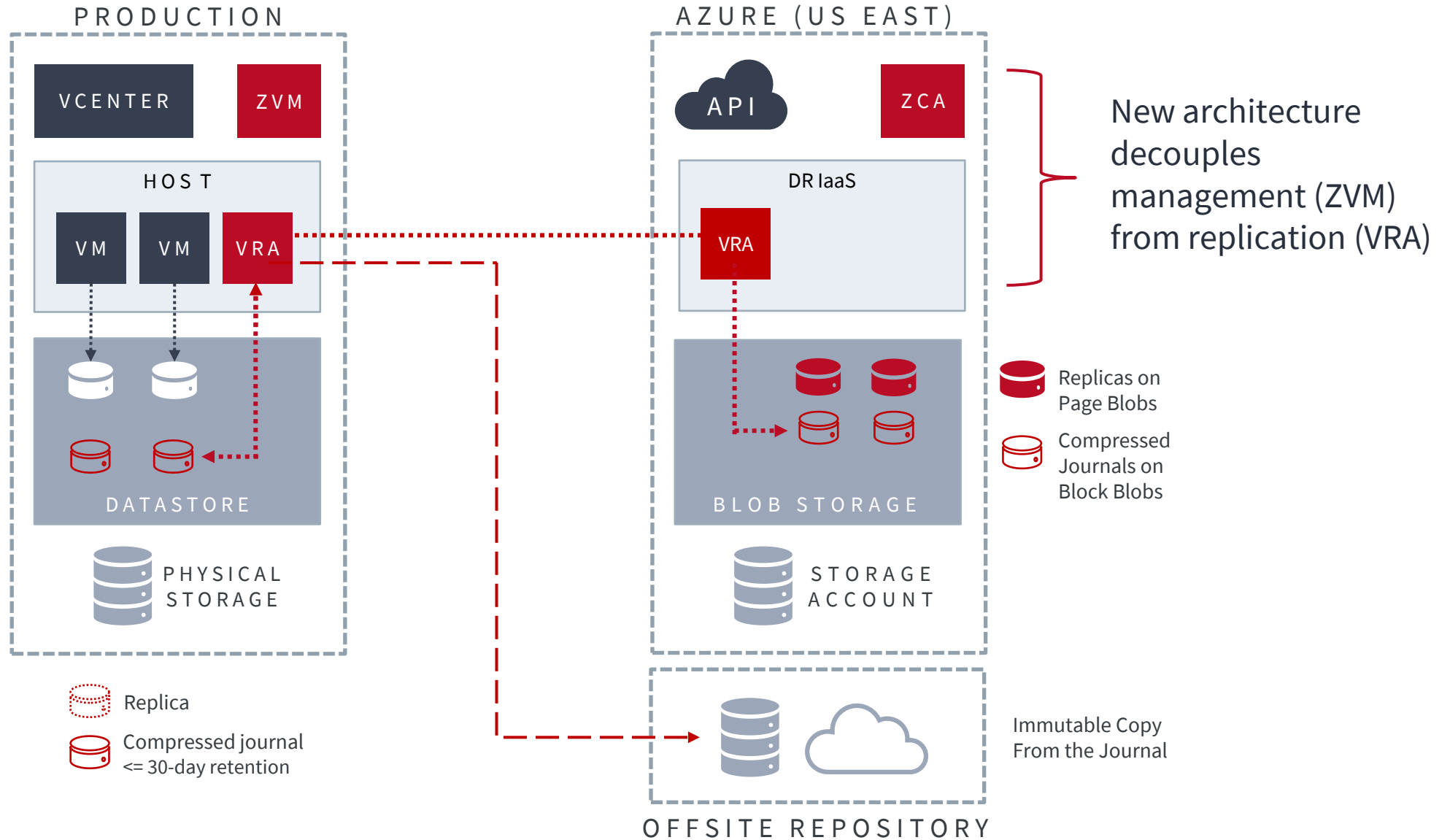

Zerto for Azure Architectures: Hybrid from Cloud

DR from Azure to On-Premises

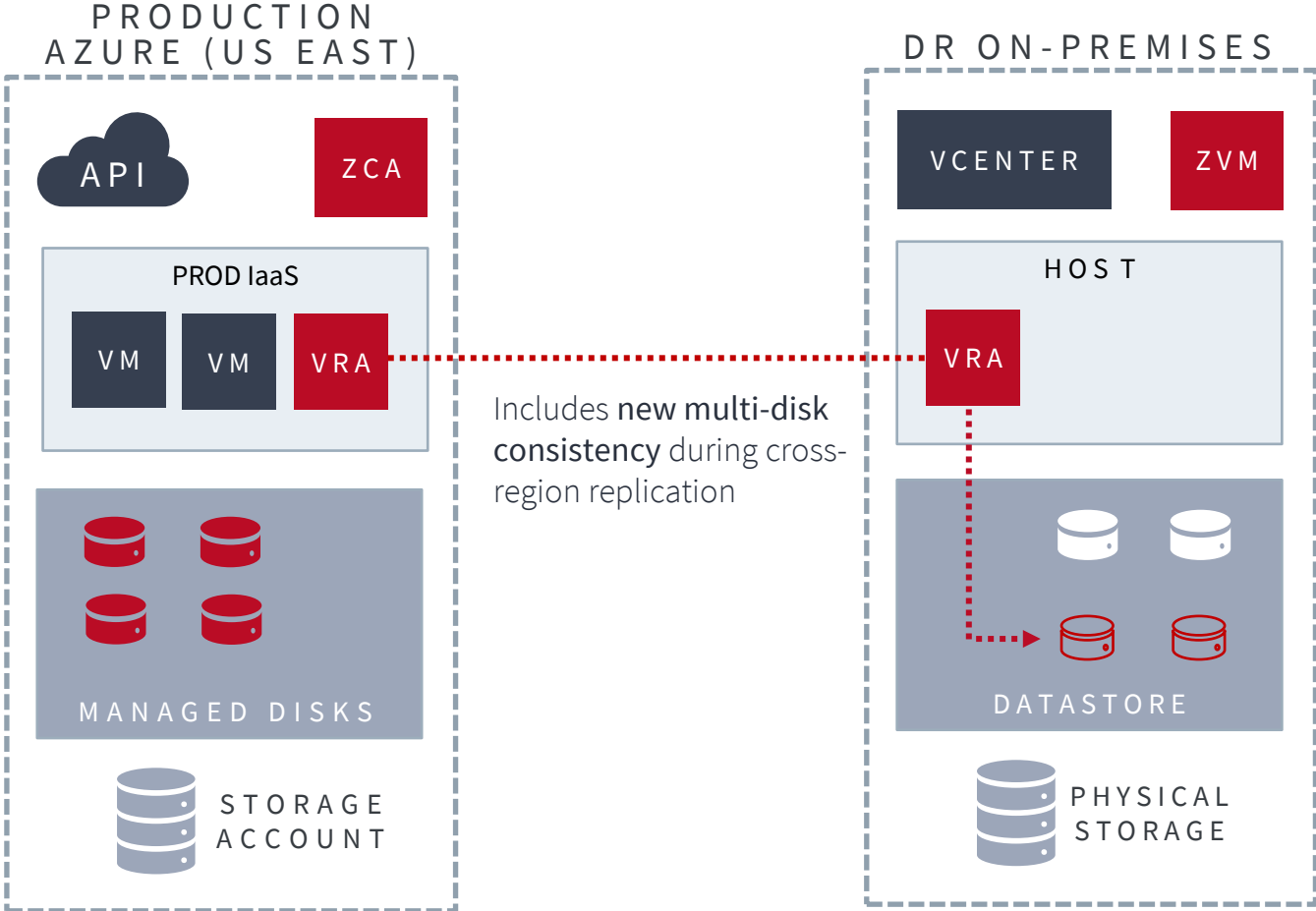

Key Benefits



SCALE: grow your business at your own pace with agentless support for thousands of cloud VMs



SIMPLICITY: faster time-to-value and easier management even at enterprise scale



FLEXIBILITY: tailor protection based on your cloud journey from hybrid all the way to cloud-native



SECURE: reduce your risk with rapid ransomware recovery and hardened cloud appliances

Zerto

a Hewlett Packard
Enterprise company

AVAILABLE SOON ON
MICROSOFT AZURE MARKETPLACE



Summary



Real-Time
Detection

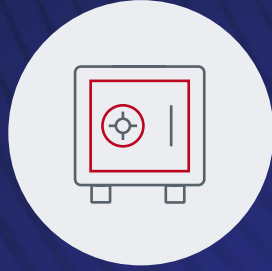

Cyber Resilience
Vault



Secure
Appliance



Protecting Azure
at Scale

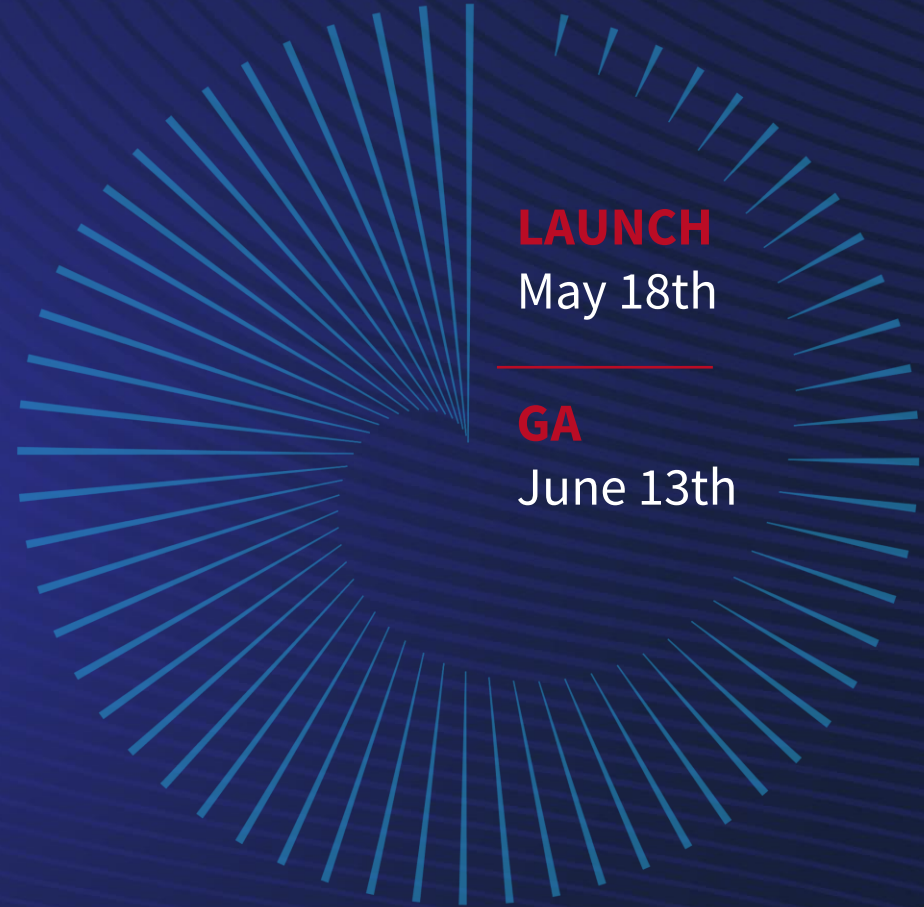

LAUNCH
May 18th

GA
June 13th

ZERTO 10

REAL-TIME DETECTION MEETS REAL-TIME PROTECTION

Join us, and our guest speaker **Kevin Mitnick**, on **May 18** for this live-streamed Zerto 10 launch event where you will hear **exciting NEW announcements!**

Register Here:



Zerto

a Hewlett Packard
Enterprise company



ZERTO 10
Real-time
Detection Meets
Real-time
Protection

Thank
You

Zerto
a Hewlett Packard
Enterprise company



ZERTO 10
Real-time
Detection Meets
Real-time
Protection



Appendix

Cyber Resilience Vault: Packaging

Four Fixed, Right-Sized Bundles

 Extra Small

100 TBs
100 VMs

 Small

300 TBs
300 VMs

 Medium

600 TBs
600 VMs

 Large

1000 TBs
1000 VMs



Zerto



HPE Alletra



HPE ProLiant



HPE Aruba

AGENDA DE 26 DE MAYO 2023

“ZERTO 10 Y SYNERGY GEN 11, ENTRE OTROS”



Intro	10:00 – 10:05	Introducción	Jaime Garrido, HPE Customer Operations
I	10:05 – 10:10	Resetear contraseña Partner Ready Portal	
	10:10 – 10:15	Estado del Partner en Partner Ready Portal	
II	10:15 – 10:25	Zerto 10	Alvaro Casado, Consultor Preventa HPE, Pleiades
III	10:25 – 10:30	Packaged Support Services de larga duración	Juan Antonio Anierte HPE CSLV
IV	10:30 – 10:40	Actualización Synergy Gen 11	Juanan Ibañez, Consultor Preventa HPE, Pleiades
V	10:40 – 10:50	Servicios a medida	Goyo Fernandez HPE CSLV
Final	10:50 – 10:55	“Call to Action” + Preguntas y Respuestas	Jaime Garrido, HPE Customer Operations

AGENDA DE 26 DE MAYO 2023

“ZERTO 10 Y SYNERGY GEN 11, ENTRE OTROS”



Intro	10:00 – 10:05	Introducción	Jaime Garrido, HPE Customer Operations
I	10:05 – 10:10	Resetear contraseña Partner Ready Portal	
	10:10 – 10:15	Estado del Partner en Partner Ready Portal	
II	10:15 – 10:25	Zerto 10	Alvaro Casado, Consultor Preventa HPE, Pleiades
III	10:25 – 10:30	Packaged Support Services de larga duración	Juan Antonio Anierte HPE CSLV
IV	10:30 – 10:40	Actualización Synergy Gen 11	Juanan Ibañez, Consultor Preventa HPE, Pleiades
V	10:40 – 10:50	Servicios a medida	Goyo Fernandez HPE CSLV
Final	10:50 – 10:55	“Call to Action” + Preguntas y Respuestas	Jaime Garrido, HPE Customer Operations

PACKAGED SUPPORT SERVICES DE 6 Y 7 AÑOS

- Desde Noviembre 2022, están disponibles los Packaged Support Services de 6 y 7 años
- Plataformas:
 - ProLiant DL **GEN11** y ML series
 - Desde marzo 2023: **Gen10+** ProLiant platforms
 - DL110 Gen10+
 - DL20 Gen10+
 - DL325 Gen10+ V2
 - DL345 Gen10+
 - DL360 Gen10+
 - DL365 Gen10+
 - DL380 Gen10+
 - DL385 Gen10+ V2
 - ML30 Gen10+

SLA disponibles

- TC Basic (9x5 NBD)
- TC Essential (24x7)
- TC+DMR (Defective Media Retention)
- <https://www.hpe.com/psnow/doc/a50007455enw>



BENEFICIOS

PARA EL VENDEDOR

- Acelerar la consecución de la cuota/objetivo de ventas
- Maximizar la venta con menos transacciones
- Aumentar el control de la cuenta
- Bloquear a la competencia por mas tiempo
- Reducir el riesgo de los TPMs

PARA NUESTROS CLIENTES

- Mejor precio anualizado
- Protección ante las subidas de precio
- Reducción la carga administrativa con menos ciclos de compras
- Reducir los gaps de soporte



ACTUALIZACION DE MATERIALES

• TECH CARE

- Actualización de datasheet
- <https://www.hpe.com/psnow/doc/a00108652enw>
- HPE Support Center is now referred to as the HPE Service Portal, and HPE InfoSight has been replaced by HPE Proprietary Service tools
- Idiomas: próximamente disponibles

• MULTIVENDOR SUPPORT

- [Multivendor Services Data Sheet](#) (NUEVO)
- [HPE Multivendor Seismic Briefcase \(HPE & Partner Use\)](#)
- [Customer Showcase Video](#)
- [Customer Presentation Deck with Speaker Notes](#)
- Idiomas: próximamente disponibles



AGENDA DE 26 DE MAYO 2023

“ZERTO 10 Y SYNERGY GEN 11, ENTRE OTROS”

Intro	10:00 – 10:05	Introducción	Jaime Garrido, HPE Customer Operations
I	10:05 – 10:10	Resetear contraseña Partner Ready Portal	
	10:10 – 10:15	Estado del Partner en Partner Ready Portal	
II	10:15 – 10:25	Zerto 10	Alvaro Casado, Consultor Preventa HPE, Pleiades
III	10:25 – 10:30	Packaged Support Services de larga duración	Juan Antonio Anierte HPE CSLV
IV	10:30 – 10:40	Actualización Synergy Gen 11	Juanan Ibañez, Consultor Preventa HPE, Pleiades
V	10:40 – 10:50	Servicios a medida	Goyo Fernandez HPE CSLV
Final	10:50 – 10:55	“Call to Action” + Preguntas y Respuestas	Jaime Garrido, HPE Customer Operations

AGENDA DE 26 DE MAYO 2023

“ZERTO 10 Y SYNERGY GEN 11, ENTRE OTROS”

Intro	10:00 – 10:05	Introducción	Jaime Garrido, HPE Customer Operations
I	10:05 – 10:10	Resetear contraseña Partner Ready Portal	
	10:10 – 10:15	Estado del Partner en Partner Ready Portal	
II	10:15 – 10:25	Zerto 10	Alvaro Casado, Consultor Preventa HPE, Pleiades
III	10:25 – 10:30	Packaged Support Services de larga duración	Juan Antonio Anierte HPE CSLV
IV	10:30 – 10:40	Actualización Synergy Gen 11	Juanan Ibañez, Consultor Preventa HPE, Pleiades
V	10:40 – 10:50	Servicios a medida	Goyo Fernandez HPE CSLV
Final	10:50 – 10:55	“Call to Action” + Preguntas y Respuestas	Jaime Garrido, HPE Customer Operations



SYNERGY – AN INTELLIGENT SOFTWARE DEFINED INFRASTRUCTURE

Truly Composable DataCenter

Composable Fabric

Composable Compute

Composable Storage



HPE SYNERGY COMPUTE



HPE SYNERGY 480 - GENERATIONAL IMPROVEMENTS

SY480 Gen10



Gen10 (Sky Lake & Cascade Lake)

- 1st/2nd Generation of Scalable Performance Processors
- PCIe 3.0 IO
- 6 Channel/12 DIMMs per Socket Memory
- 2 Drive Base and Premium (NVMe) Storage, with boot from SAN
- Security, iLO4 Silicon Root of Trust

SY480 Gen10 Plus



Gen10 Plus (Ice Lake)

- 3rd Generation of Scalable Performance Processors w/ new performance increase over previous)
- PCIe 4.0 IO
- DDR4 8 Channel/16 DIMMs per Socket Memory
- 2 and 4 Drive Solutions w/ SAS/SATA & NVMe options and boot from SAN
- 2x Drive M.2 Boot solution
- Security, iLO5 Silicon Root of Trust

SY480 Gen11



Gen11 (Sapphire Rapids)

- **4th Generation of Scalable Performance Processors (up to 15% performance increase over previous)**
- **PCIe 5.0**, more IO bandwidth with CXL v1.1.
- **DDR5-4800 Memory** w/ 8 Channel/16 DIMMs/Socket providing substantial performance boost
- **New Tri-Mode RAID controller (front/rear)**
- 2 & 4 Drive Solutions w/ SAS/SATA /NVMe & a new 8 Drive EDSFF E3.S NVMe options and boot from SAN/VSAN
- NS204i-d, 2 Drive M.2 NVMe Boot
- Security, iLO6 Silicon Root of Trust

HPE SYNERGY 480 GEN11 COMPUTE MODULE—WHAT'S NEW

- **Single Base Model CTO SKU with optional Drive Cage Options**
Reduced customer complexity while offering increased flexibility & opportunity for change as business requirements change
- **Intel's 4th Generation of Xeon Scalable Family processors**
Expect largest increase in performance to date providing the customer with better response times with all workloads - virtualized, VDI, and general purpose business workloads
- **New DDR5 Memory @ PCIe 5.0 I/O, 8 channel Memory on 32 DIMMs - offers 50%* more data bandwidth and performance and up to 4TB per socket capacity**
New levels of performance and bandwidth provide even faster response times to data intensive workloads
- **Unique Storage solutions with 2x & 4x SAS/SATA/NVMe, 4x NVMe Direct Drive and 8x EDSFF E3.s Flash Drives all driven from Direct Connect/VROC or a Tri-Mode Controller**
Offers customers flexibility in boot & storage solutions while offering new options for VSAN operations
- **HPE Synergy Compute continues to work with existing HPE Synergy Frames, current options, & the latest version of HPE Composer2 / OneView**
Offers customers the most flexibility & performance with the least disruption

- PCIe 5.0 support will be dependent on PCIe 5.0 product offering to drive controllers and networking. PCIe 4.0 devices will continue to operate at 4.0 speed.
- All drive solutions for Gen11 will be unique to Synergy 480 Gen11 product and will use BC- Basic Carrier Drives..



SY480 GEN11 DEPLOYMENT STRATEGY—MODULAR CHASSIS

Continuing previous gen deployment strategy providing customer flexibility to change

Total number of 2 Base SKUs

- HPE SY480 Gen11 CTO Compute Module
- HPE SY480 Gen11 TAA CTO Compute Module



New SY480 Gen11—Base product

Key Required Options:

- Drive Cages/Boot & Storage Options
- Processors
- Memory
- Fabric Options

Front Cage Drive Selection Options (CTO or BTO)

- HPE SY480 Gen11 w/O Front Drive Kit
- HPE SY480 Gen11 Premium 2SFF Drive Kit (SATA/SAS/NVMe)
- HPE SY480 Gen11 Premium 4SFF Drive Kit (SATA/SAS/NVMe)
- HPE SY480 Gen11 4SFF Direct Connect Drive Kit (NVMe)
- HPE SY480 Gen11 8EDSFF E.3 Direct Connect Drive Kit (NVMe)

**available May'23*

No Drive



2 SFF Premium



4 SFF Premium



4 Drive Direct Connect



8 Drive EDSFF E3.S Direct Connect*

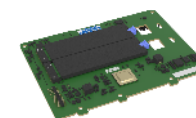



HW RAID 2x 480 GB M.2
Drive Option
(may be used with any option above)

**available May'23*

SY480 GEN11: CONTROLLER SUPPORT PER BACKPLANE

Gen11 Controller/Backplane choices:

		No Controller	VROC	NS204i-d 	SR416ie-m 
Drive-less 		✓	✗	✓	D3940 only
2dr Premium SFF 		✗	✗	✓	D3940 and 2SFF front bays
4dr Premium SFF 		✗	✗	✓	D3940 and 4SFF front bays
4dr Direct Connect SFF 		✓	✓	✓	D3940 only
8dr Direct Connect EDSFF* 		✓	✓	✓	D3940 only

**available May'23*



HPE SYNERGY COMPUTE ROADMAP

Gen10 Cascade Lake

DISC:
4/30/2024

Gen10 Plus Ice Lake

DISC:
7/31/2024

Synergy Generations

Gen11 Sapphire Rapids

Gen11 EMR
Refresh

2022

2023

2024

HPE SYNERGY INFRASTRUCTURE



HPE SYNERGY INFRASTRUCTURE ENHANCEMENTS

High-Capacity Fan to Support Gen 11



- New high-capacity fan to support SY480 Gen11 Compute Modules
- Standard fan for new SY12000 frames
- Backwards compatible with existing Synergy 12000 frames
- *Required for all SY480 Gen11 installations*
- *Requires Composer2 and min FLM 4.x firmware version*

New Synergy 12000 Frame SKU



- New Synergy 12000 frames being introduced alongside SY480 Gen11
- Adds support for factory integrations of the new high-capacity fans
- Compatible with all currently shipping Synergy compute modules and options
- Will have both TAA and non-TAA versions available
- *Required for new SY480 Gen11 factory integrations*

New Dual Slot Power Supply Adapter



- New power option to support higher power configurations
- Highest capacity Synergy power solution providing up to 4400W per bay
 - 66% more power than standard 2650W PSU
 - Leverages 2 of the new 1800-2200W Flex Slot PSUs
 - Backwards compatible with existing Synergy 12000 frames
- *Requires Composer2 and min FLM 4.x firmware version*

SYNERGY HIGH-CAPACITY FAN

Current Fan



New High-Capacity Fan



Distinguished by new fan graphic on assembly

High-Capacity Fan
- SKU: P51175-B21

SYNERGY POWER SUPPLIES

Wide Range of HPE Synergy Power Supply Options Available

HPE 2650W Power Supply Kit

Standard Synergy Power Supply

Supports input voltage range of 200-240VAC



HPE 3000W Power Supply Kit*

High Capacity Synergy Power Supply

Choose this power supply when the datacenter input voltage is

208VAC



HPE 3400W Power Supply Kit

High-Capacity Synergy Power Supply

Choose this power supply when the datacenter input voltage is

230-240VAC



HPE Dual Slot Power Supply Adapter
Future

Support for Highest Capacity Synergy Power Supply 1800-2200W
Provides up to 4400W (2x2200) per bay
Supports input voltage range of

200-240VAC



All Synergy configurations must be validated through HPE Power Advisor



*Option available in NA only

HPE SYNERGY DUAL SLOT POWER SUPPLY ADAPTER

Dual Slot Power Supply Adapter – PCA Interposer

- Serviceable module providing physical support for the SY12000 Frame only
- Support up to 2200W Flex Slot power supplies per power bay with a total power up to 4400 Watts
- Combines outputs of both power supplies into one input to the Frame
- Provides CAN bus communication interface to Synergy management
- Provides programming mechanism

Flex Slot Power Supplies

- Leverages the common power supply used by ProLiant compute modules (Rack, Tower, & Apollo systems)
- HPE Synergy will support the 1800-2200W Ti Flex Slot Power Supply SKU: P44712-B21

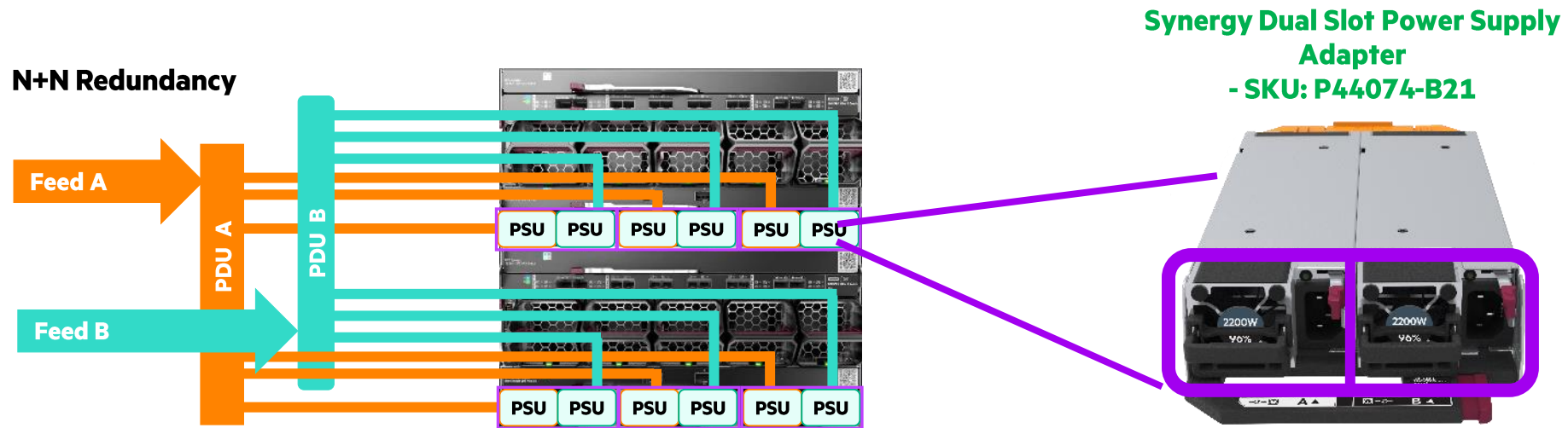

HPE SYNERGY NETWORK



HPE SYNERGY FABRIC ADAPTERS

Gen11 Solutions

- P39959-B21, HPE SR416ie-m Gen11 Storage Ctrlr
- 876449-B21, HPE Synergy 4820C 10/20/25Gb Converged Network Adapter
- P02054-B21, HPE Synergy 6820C 25/50Gb Converged Network Adapter
- 870828-B21, HPE Synergy 5330C 32Gb Fibre Channel Host Bus Adapter
- 777456-B21, HPE Synergy 5830C 32Gb Fibre Channel Host Bus Adapter



Converged Network Adapter



Fibre Channel Host Bus Adapter



Information subject to substantial uncertainties, could change at any time without prior notification

HPE SYNERGY STORAGE – WHAT’S AROUND THE CORNER

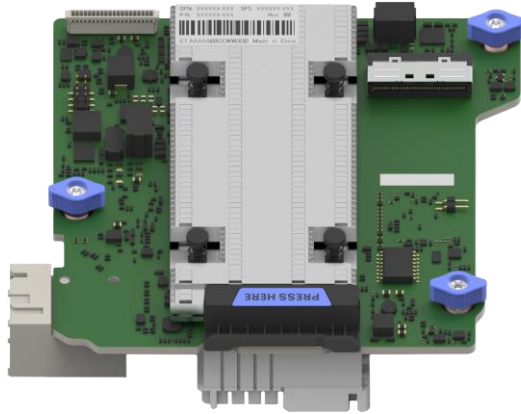

Gen11 SR416ie-m

New Storage Controller

- Tri-Mode support for PCIe Gen4 NVMe, 24G SAS and 6G SATA
- Supports both Secure Boot and SPDM Gen11 security features
- Simplifies customer experience by streamlining options and offering broad-scale support



Alletra 9000¹

Alletra 9000 Flat SAN Support

- All NVMe solution designed for mission-critical workloads with 100% availability guaranteed
- Intent-based Provisioning intelligently provisions application workloads on infrastructure best-suited for optimizing SLAs

1. Alletra 9000 flat SAN support to be delivered summer 2023.

HPE SYNERGY SOFTWARE



SYNERGY SOFTWARE RELEASES

News and Updates

In order to provide Synergy customers a more customizable and time-to-market software update experience, we have introduced Synergy hotfix capabilities to allow customers to install critical security/bug fixes in the timeliest manner possible.

HPE Synergy Service Pack (SSP)

A dedicated service pack has been created with the name HPE Synergy Service Pack (SSP). This dedicated service pack enables Synergy customers to use the HPE SSP as a base which can be customized to apply HPE Synergy hotfixes.

Beginning in May 2021, all HPE Synergy Software Releases will adopt the new name.

HPE Synergy Hotfix Releases

Flexible Update Options for Critical Releases

HPE Synergy hotfixes will be released to provide Synergy customers a method to install critical fixes between official HPE Synergy Service Pack (SSP) releases.

Each of Synergy hotfix release will have

- Customer advisory
- Instructions for installation
- Release compatibility details for SSP & OneView versions

Synergy hotfixes will also appear on the [Synergy Software Overview page](#).

Next

Expand support of more flexible, independent updates

SYNERGY SOFTWARE RELEASES & OPERATING SYSTEM SUPPORT

Year at-a-Glance

Current

Latest Release SSP 2022.11.01

New OS Enablement and Ongoing OS Support
OS Support Gen10 / Gen10 Plus

- VMware ESXi vSAN 7.0u2, 7.0u3, **8.0**
- Red Hat RHEL 8.5, 8.6, 9.0
- SUSE SLES 12 SP5, SLES 15 SP3, **SLES 15 SP4**
- Microsoft Windows WS 2016 RS1, WS 2019 RS5, 2022

Released 8-November-22

Synergy Hotfixes

None

Active Synergy SPP/SSP releases:

Synergy SSP 2021.11.01
Synergy SSP 2022.02.01 and .02
Synergy SSP 2022.08.01
Synergy SSP 2022.11.01

Future

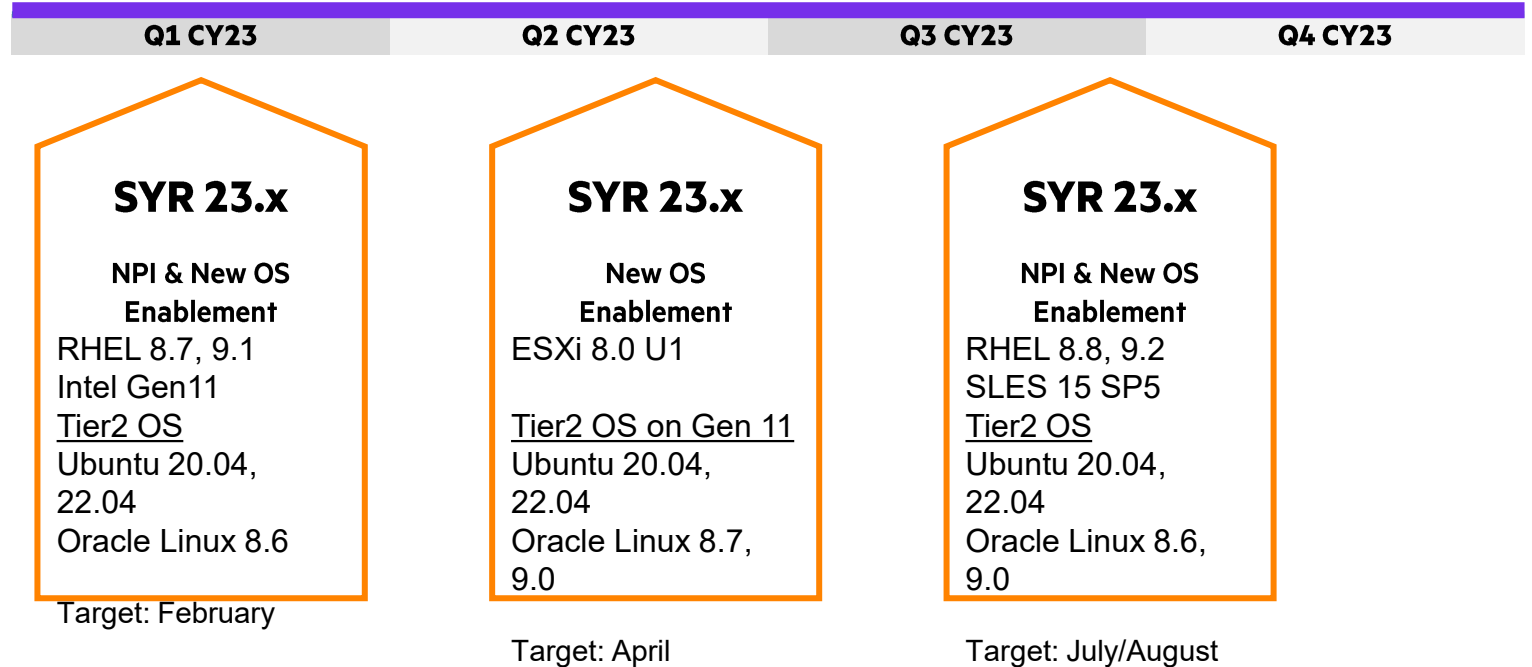

Note: This roadmap is subject to change without notice.

HPE ONEVIEW ALIGNMENT WITH HPE SYNERGY CUSTOM SPP

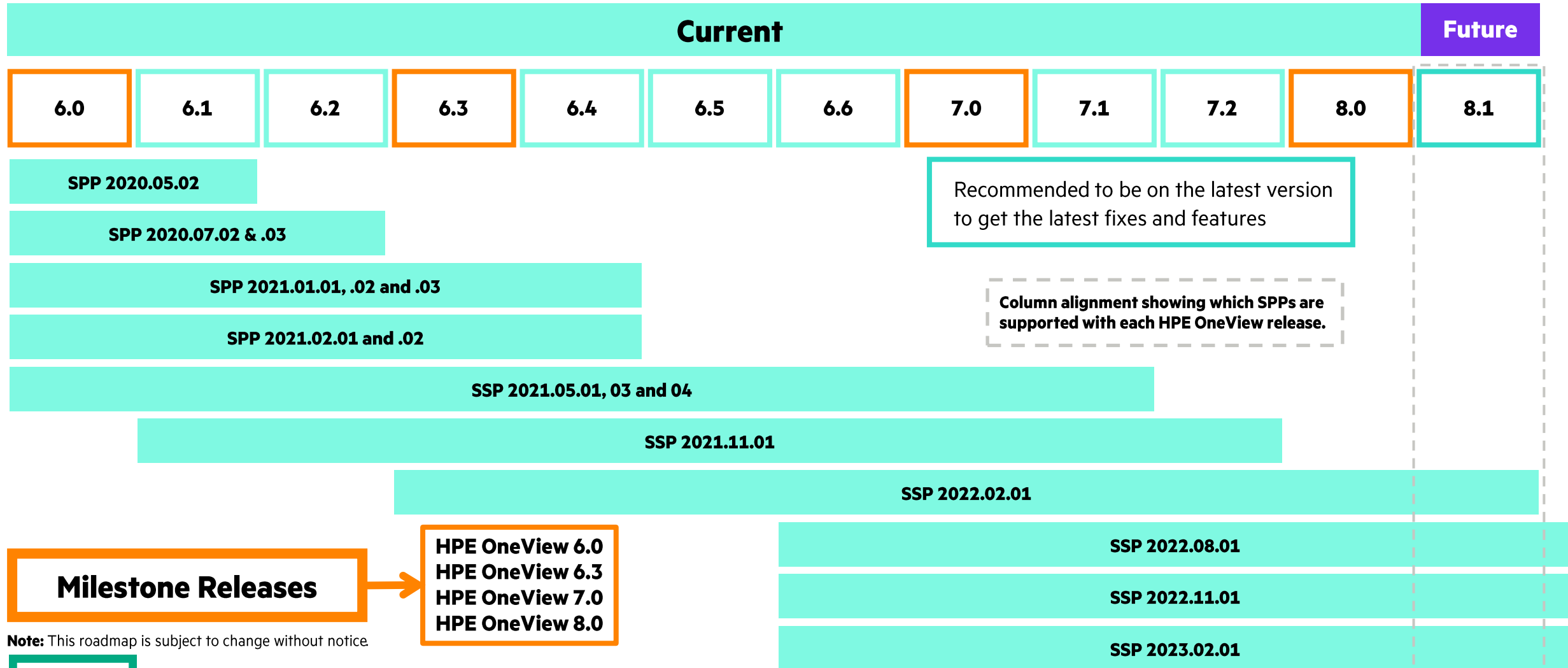

AGENDA DE 26 DE MAYO 2023

“ZERTO 10 Y SYNERGY GEN 11, ENTRE OTROS”

Intro	10:00 – 10:05	Introducción	Jaime Garrido, HPE Customer Operations
I	10:05 – 10:10	Resetear contraseña Partner Ready Portal	
	10:10 – 10:15	Estado del Partner en Partner Ready Portal	
II	10:15 – 10:25	Zerto 10	Alvaro Casado, Consultor Preventa HPE, Pleiades
III	10:25 – 10:30	Packaged Support Services de larga duración	Juan Antonio Anierte HPE CSLV
IV	10:30 – 10:40	Actualización Synergy Gen 11	Juanan Ibañez, Consultor Preventa HPE, Pleiades
V	10:40 – 10:50	Servicios a medida	Goyo Fernandez HPE CSLV
Final	10:50 – 10:55	“Call to Action” + Preguntas y Respuestas	Jaime Garrido, HPE Customer Operations



AGENDA DE 26 DE MAYO 2023

“ZERTO 10 Y SYNERGY GEN 11, ENTRE OTROS”

Intro	10:00 – 10:05	Introducción	Jaime Garrido, HPE Customer Operations
I	10:05 – 10:10	Resetear contraseña Partner Ready Portal	
	10:10 – 10:15	Estado del Partner en Partner Ready Portal	
II	10:15 – 10:25	Zerto 10	Alvaro Casado, Consultor Preventa HPE, Pleiades
III	10:25 – 10:30	Packaged Support Services de larga duración	Juan Antonio Anierte HPE CSLV
IV	10:30 – 10:40	Actualización Synergy Gen 11	Juanan Ibañez, Consultor Preventa HPE, Pleiades
V	10:40 – 10:50	Servicios a medida	Goyo Fernandez HPE CSLV
Final	10:50 – 10:55	“Call to Action” + Preguntas y Respuestas	Jaime Garrido, HPE Customer Operations



WHAT ARE HPE LIFECYCLE SERVICES ?

Outcome based services for every stage of the IT lifecycle that—

- Augment & boost customer IT expertise
- Enable technology outcomes
- Accelerate time to value
- Provide for single & multiple per event engagements

All HPE Lifecycle Services are orderable as a SKU & can be quoted with hardware or separately. Predefined & custom packages available

Outcome based services for every stage of the IT lifecycle

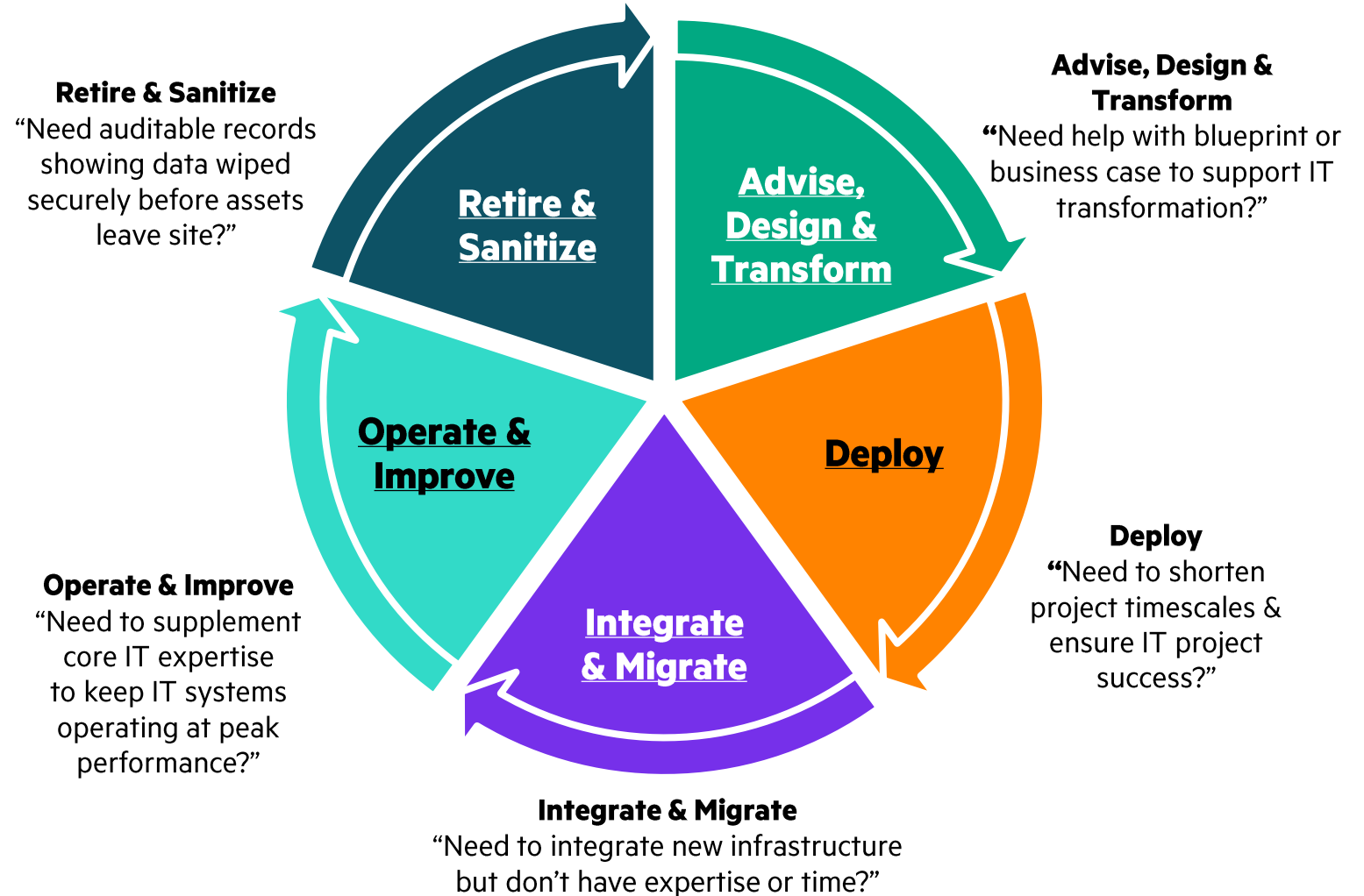

DEPLOY—ALL PROJECTS, ALL SIZES



Install / Install & Start Up

- Small scale, add-on to environment
- Transactional, repeatable
- HPE & HPE PRSD delivered



Factory Integration Services

- Pre-built to customer specification
- Pre configured & tested to shorten project time
- Scalable, repeatable, economies of scale



Custom

- Large scale global capability
- HPE & non HPE
- Meets most demanding customer requirements

INTEGRATE & MIGRATE AT A GLANCE

Integrate new technology with existing

- Integrate HPE & non-HPE environments
- Rely on HPE expertise & knowledge

&

Securely Migrate Data

- Move data from HPE & non HPE platforms
- Leverage HPE tools & methods
- Rely on HPE expertise

&

Protect the business when moving IT hardware

- Relocate to same or new site
- Recertify if moved without HPE

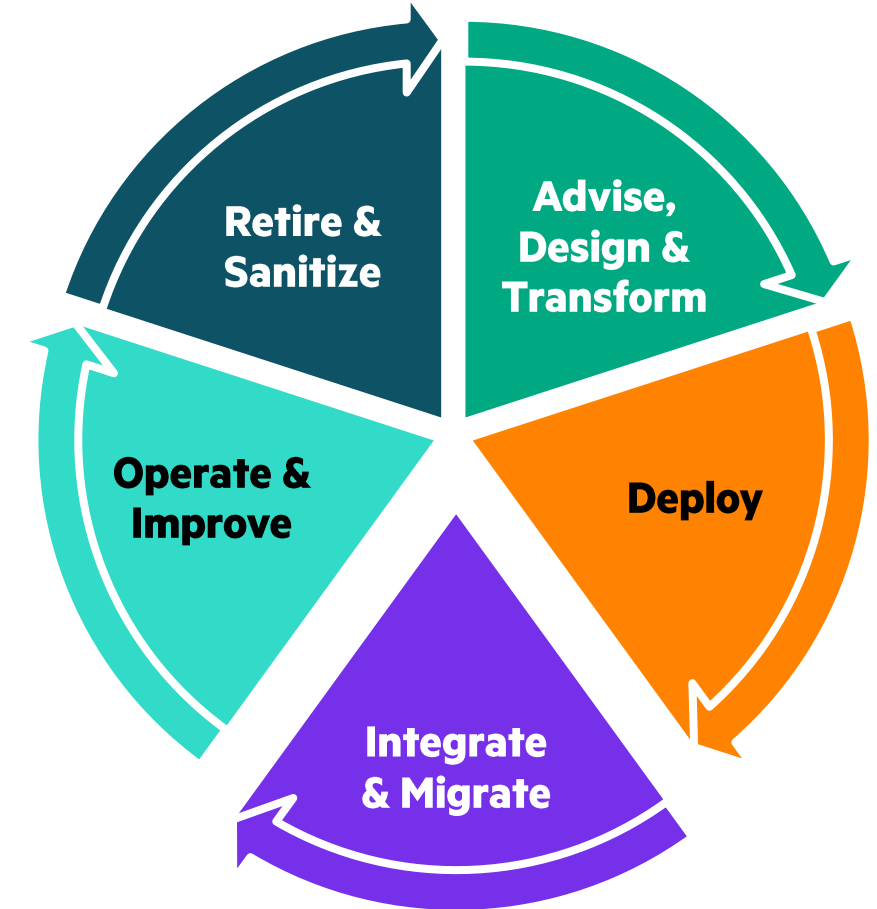
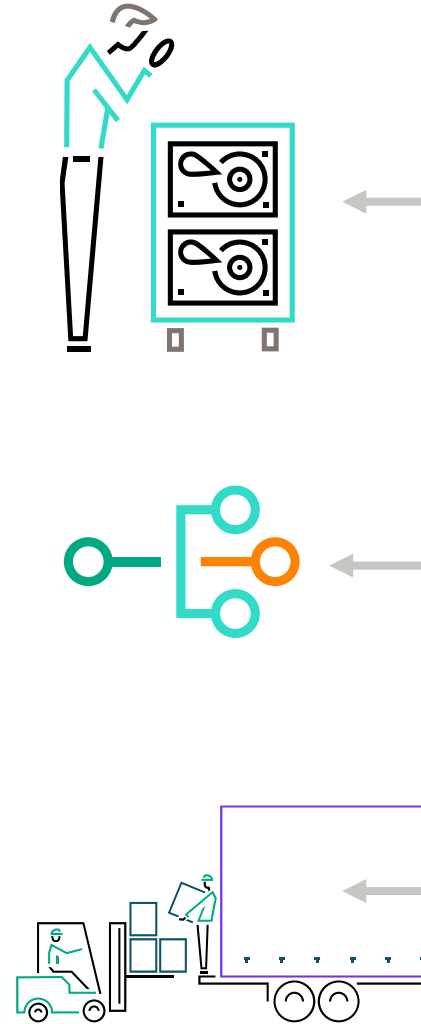

OPERATE & IMPROVE AT A GLANCE

Boost core IT capacity & capability

- HPE Team Days &
- HPE Resource Offers

or

Select from range of services including

- Firmware Update Analysis & Implementation
- Health-Checks
- IT Performance Services

or

Redeem HPE Service Credits

- Flexibility at any time for any service on the Menu

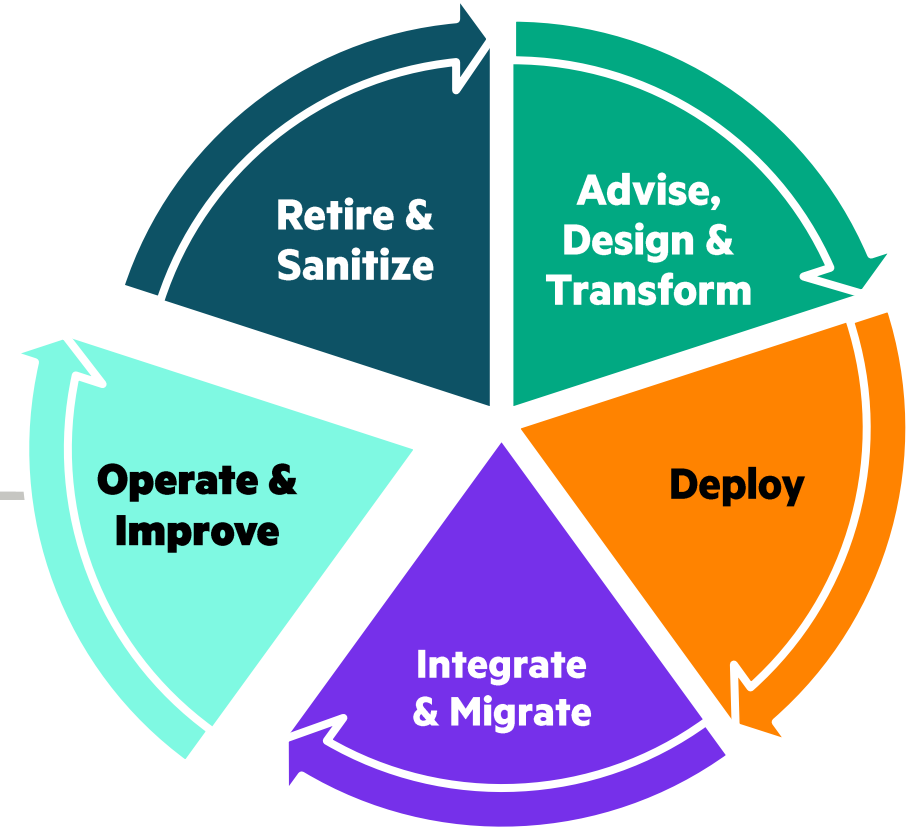
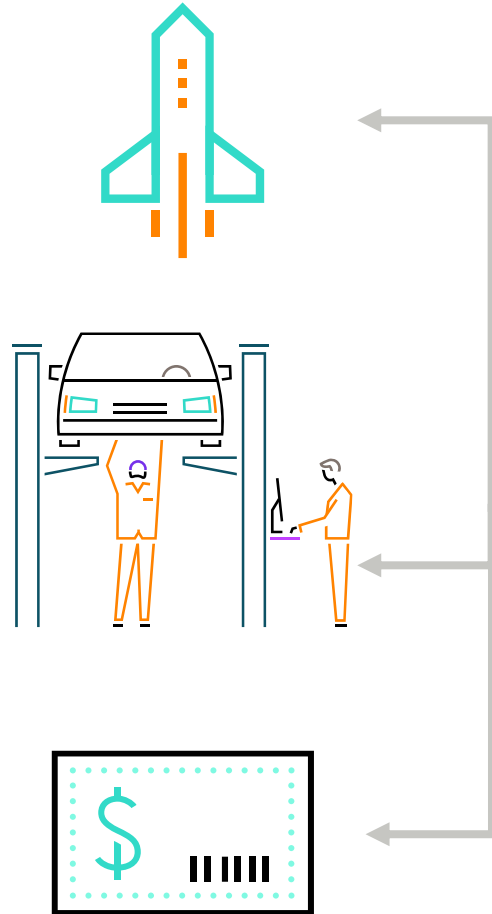

RETIRE AND SANITIZE AT A GLANCE

Protect Data

- Avoid data breaches & **sizeable fines**
- Wipe drives securely **on-site**
- Get **certificate** of erasure

&

Fund new investments with retired IT hardware

- **Get money back!**
- **Free up space**
- Eco friendly disposal

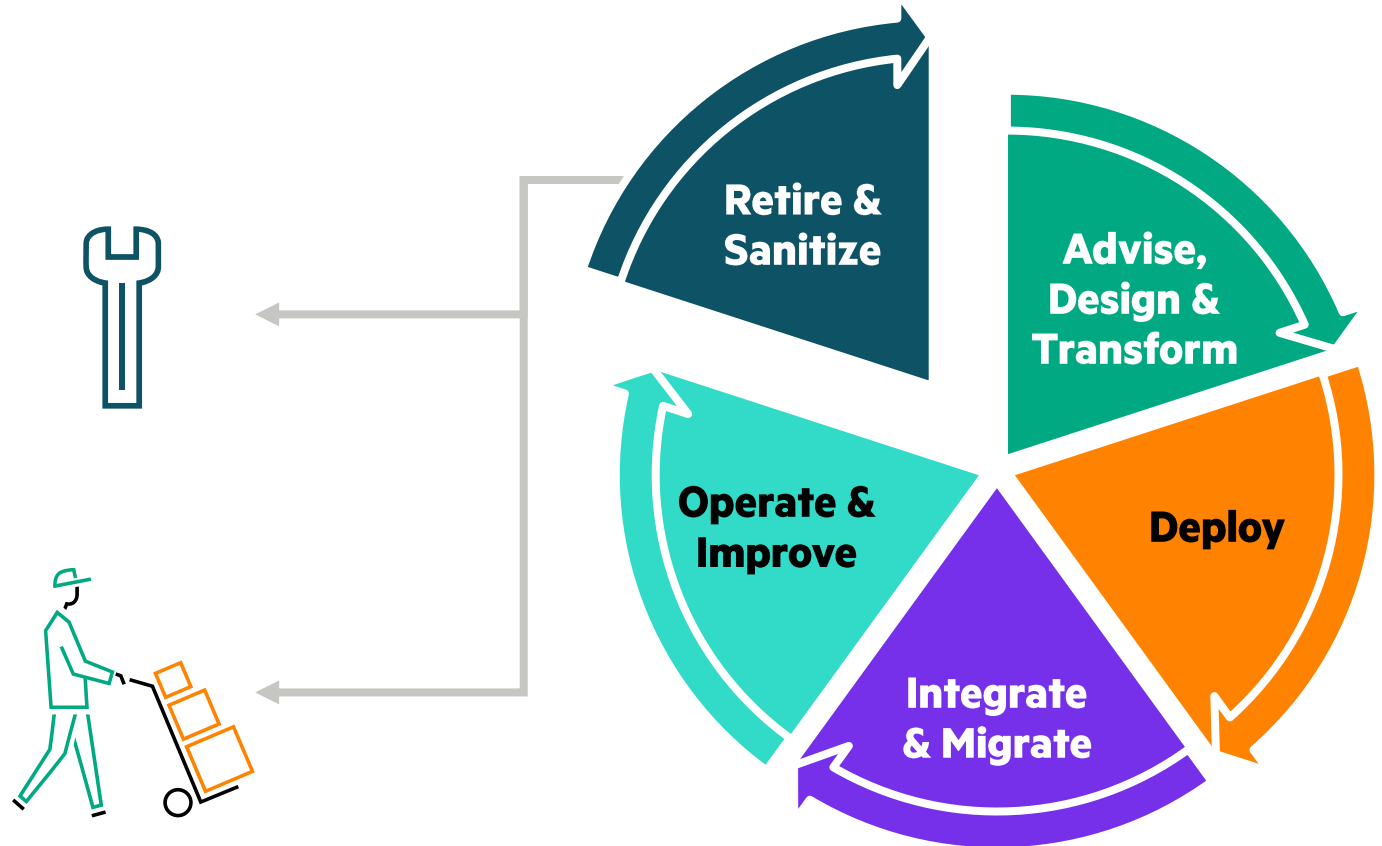

HELP CUSTOMERS SHORTEN TIME TO VALUE WITH SERVICE CREDITS

Get fast & flexible access to HPE expertise with access to over 100 services on the Menu

Sample Services on the Menu

	Server	Storage	Networking & Security	Software	Cloud
Infrastructure	<ul style="list-style-type: none">• SW & FW Analysis• SW & FW Update Service• System Health Check• Media Sanitization• Performance Services	<ul style="list-style-type: none">• SW & FW Analysis + Updates• Capacity & Trending• Back Up & Recovery Check (disk)• Data Sanitization• Performance Services	<ul style="list-style-type: none">• Predictive Wireless Site Survey• Security Assessment for Remote Workforce• Network Vulnerability Assessment & Pen Testing• Application Vulnerability Assessment & Pen Testing	<ul style="list-style-type: none">• Performance Analysis (Linux)• SAP HANA Versioning Services• SAP Solution Manager Health Check• HPE OneView (use time blocks)	<ul style="list-style-type: none">• Cloud Workshops• Cloud Assessment• Cloud Planning• Cloud Implementation• For Private & Public Environments
Assessment & Improvement	<ul style="list-style-type: none">• Assessment services to identify operational risk or improvements in IT performance or reduce downtime & complexity across Server, Storage & Networking platforms				
Technical Resource	<ul style="list-style-type: none">• Leverage HPE technical expertise to help with specific technical challenges to supplement in-house skills.				

-
- [Pweb](#)

POCKET GUIDE

HPE BEST PRACTICES—FOR OPTIMAL HARDWARE PERFORMANCE

HPE 3PAR STORESERV, HPE PRIMERA & HPE ALLETRA MAINTENANCE SCHEDULE

Best Practice—Gold Standard

Health Check

Assessment of overall health, operational state, performance, capacity, and supportability of the HPE 3PAR system.

Firmware Update Analysis

Provides report with current and recommended FW and SW revisions including compatibility analysis of all affected products.

Firmware Update Implementation

Provides remote or on-site implementation of FW and SW revisions for products classified as user-updatable.

Performance and Capacity Trending

Periodic high-level performance and capacity report to identify trends and emerging issues.

Rebalance Service

Analysis, planning, and implementation to balance I/O across HPE 3PAR when adding capacity. Includes electronic data movement and physical drive movement as needed.

Data Sanitization

Performs hard drive or solid-state drive erasure on storage arrays to industry standards (DoD 5220.22-M, NIST 800-88) to facilitate repurposing, resale, or disposal when repurposing or retiring drives.

	Year 1				Year 2				Year 3				Year 4				Year 5			
	Q1	Q2	Q3	Q4	Q1	Q2	Q3	Q4	Q1	Q2	Q3	Q4	Q1	Q2	Q3	Q4	Q1	Q2	Q3	Q4
Health Check	•		•		•		•		•		•		•		•		•		•	
Firmware Update Analysis	•		•		•		•		•		•		•		•		•		•	
Firmware Update Implementation	•		•		•		•		•		•		•		•		•		•	
Performance and Capacity Trending			•				•				•				•				•	
Rebalance Service							•								•					•
Data Sanitization																				•

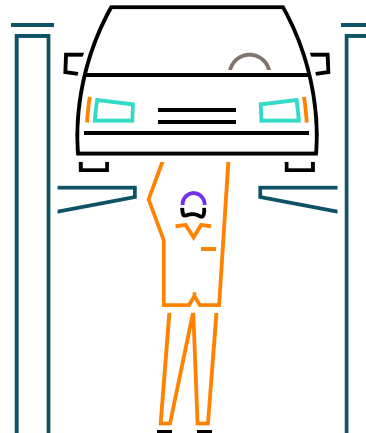

- **Example** shows **services required over 5 years**
- **Similar to servicing a car**, all maintenance checks are required for optimal performance
- Some services are **required more often** than others
- **HPE Service Credits** offers a **flexible solution** supplementing in-house IT departments when required

Sample maintenance schedule. **Note:** Service intervals will vary per customer.

HPE 3PAR STORESERV, HPE PRIMERA & HPE ALLETRA MAINTENANCE SCHEDULE

Recipe for success using HPE Service Credits—example 5 years, single array

	Mission-critical arrays HPE StoreServ 20000/10000/84xx/74xx models				Non-business-critical HPE StoreServ 82xx/72xx models			
	#Cr/Svc	#/YR	YR	Yearly Cr	#Cr/Svc	#/YR	YR	Yearly Cr
Health Check	10	2	5	100 Cr	10	2	5	100 Cr
OS Firmware Update Analysis	20	2	5	200 Cr	20	1	5	100 Cr
OS Firmware Update Implementation	15*	2	5	150 Cr	10–15*	2	5	150 Cr
Performance and Capacity Trending	35	1	5	175 Cr	35	1	5	175 Cr
Rebalance	25–50	1	5	250 Cr	25–50	0	5	0 Cr
Data Sanitization	50	1		50 Cr	20	1		20 Cr
Total for 5 years				925 Cr				545 Cr

This is a Sample maintenance schedule. **Note:** Service intervals will vary per customer 15 credits for on-site delivery or otherwise 10 credits for remote delivery.

* Number of credits will vary based on HW. Out of hours delivery will increase credits cost

950 Credits (5 year) = 223K WW list \$

550 credits (5 year) = 129K WW list \$

CONFIDENTIAL | AUTHORIZED HPE PARTNER USE ONLY

HPE SYNERGY MAINTENANCE SCHEDULE

Best Practice—Gold Standard

HPE Synergy Ecosystem Health Review

Provides a review of status, configuration, security, firmware, driver, and software versions.

HPE Synergy FW Update Analysis

Provides report with current and recommended firmware and software revisions, including compatibility analysis with all affected components.

HPE Synergy FW Update Implementation

Provides upgrade to current and/or recommended FW and SW revisions, according to compatibility analysis with affected components.

Data Sanitization

Performs hard drive or solid-state drive erasure on storage arrays to industry standards (DoD 5220, NIST 800-88) to facilitate repurposing, resale, or disposal when repurposing or retiring drives.

	Year 1				Year 2				Year 3				Year 4				Year 5			
	Q1	Q2	Q3	Q4	Q1	Q2	Q3	Q4	Q1	Q2	Q3	Q4	Q1	Q2	Q3	Q4	Q1	Q2	Q3	Q4
		•					•				•				•				•	
	•		•		•		•		•		•		•		•		•		•	
	•		•		•		•		•		•		•		•		•		•	
																				•

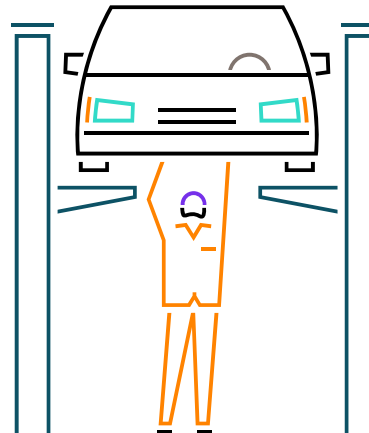

- **Example** shows **services required over 5 years**
- **Similar to servicing a car**, all maintenance checks are required for optimal performance
- Some services are **required more often** than others
- **HPE Service Credits offers a flexible solution** supplementing in-house IT departments when required

Sample maintenance schedule. **Note:** Service intervals will vary per customer.

HPE SYNERGY MAINTENANCE SCHEDULE

Recipe for success using HPE Service Credits—example single management ring, 3 frames, 5 years

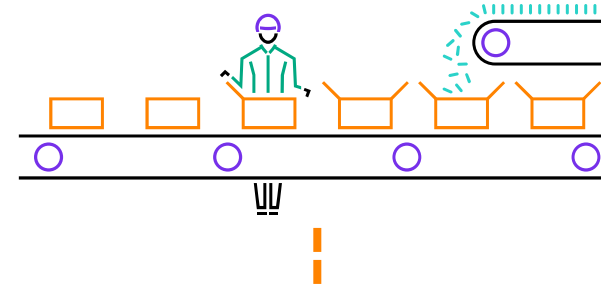

	Number credits per service	Annual recommendation	Term (Years)	Total credits over term
HPE Synergy Ecosystem Health Review	10*	1	5	50 Cr
HPE Synergy Firmware Update Analysis	20	2	5	200 Cr
HPE Synergy Firmware Update Implementation	25	2	5	250 Cr
Data Sanitization	20	1**		20 Cr
Total for 5 years				520 Cr

550 credits (5 year) = **129K WW list \$**

* Environments of more than four logical enclosures will require additional credits

** Required once at the end of the lifecycle of the asset

Sample maintenance schedule. **Note:** Service intervals will vary per customer.

AGENDA DE 26 DE MAYO 2023

“ZERTO 10 Y SYNERGY GEN 11, ENTRE OTROS”

Intro	10:00 – 10:05	Introducción	Jaime Garrido, HPE Customer Operations
I	10:05 – 10:10	Resetear contraseña Partner Ready Portal	
	10:10 – 10:15	Estado del Partner en Partner Ready Portal	
II	10:15 – 10:25	Zerto 10	Alvaro Casado, Consultor Preventa HPE, Pleiades
III	10:25 – 10:30	Packaged Support Services de larga duración	Juan Antonio Anierte HPE CSLV
IV	10:30 – 10:40	Actualización Synergy Gen 11	Juanan Ibañez, Consultor Preventa HPE, Pleiades
V	10:40 – 10:50	Servicios a medida	Goyo Fernandez HPE CSLV
Final	10:50 – 10:55	“Call to Action” + Preguntas y Respuestas	Jaime Garrido, HPE Customer Operations



AGENDA DE 26 DE MAYO 2023

“ZERTO 10 Y SYNERGY GEN 11, ENTRE OTROS”

Intro	10:00 – 10:05	Introducción	Jaime Garrido, HPE Customer Operations
I	10:05 – 10:10	Resetear contraseña Partner Ready Portal	
	10:10 – 10:15	Estado del Partner en Partner Ready Portal	
II	10:15 – 10:25	Zerto 10	Alvaro Casado, Consultor Preventa HPE, Pleiades
III	10:25 – 10:30	Packaged Support Services de larga duración	Juan Antonio Anierte HPE CSLV
IV	10:30 – 10:40	Actualización Synergy Gen 11	Juanan Ibañez, Consultor Preventa HPE, Pleiades
V	10:40 – 10:50	Servicios a medida	Goyo Fernandez HPE CSLV
Final	10:50 – 10:55	“Call to Action” + Preguntas y Respuestas	Jaime Garrido, HPE Customer Operations



Quick Menu for Sales & Presales FY23-Q3



Todos los recursos para crear tus propuestas comerciales de Hybrid IT a la vista. - v.230524



Compendiums	1. Learning & Certification 2. Presales Activities	3. Deal Registration 4. System Sizing & Design	5. System & Services Configuration 6. Pricing Quote	7. TCO/ROI Analysis 8. Customer Solution Proposal
<p>► FY23 Certification Criteria <small>UPDATE!</small> Información sobre certificaciones del programa</p> <p>► HPE TECH PRO COMMUNITY Todos los recursos necesarios para técnicos certificados incluido el acceso a los Badges</p> <p>► HPE Sales Pro Plataforma en la que se unifican todos los recursos comerciales, certificaciones incluidas</p> <p>► Proposal Web Descripciones en español de sistemas y servicios.</p> <p>► Seismic Documentación de <i>Soluciones y Tecnologías</i></p> <p>► WebForums Grabaciones y Convocatorias</p> <p>► HPE Engage & Grow Programa de incentivos de ventas</p>	<p>1 ► My Learning Portal de formación y certificación, incluido el acceso a los Badges</p> <p>► Tools & Processes Training Grabaciones, calendario y registro de próximos webinars de herramientas</p> <p>► HPE Channel Webinars Plataforma de formaciones online para canal (Webinars)</p> <p>► View Certifications Detalles de cada certificación. Nuevas certificaciones Edge-to-Cloud HPE Master ASE Advantage program</p> <p>2 ► Customer Technology Center Web de Información y reservas</p> <p>► Programa Channel Demo <small>UPDATE!</small> T&Cs de FY23 Hasta 85% de descuento para tu equipo de demo</p> <p>► QuickSpecs Biblioteca HPE de Especificaciones de Sistemas</p>	<p>3 ► Integrated Quoting 2.0 (Deal Registration) Protege tu inversión Técnica-Preventa. Deal Registration T&Cs de FY23Q3 <small>NEW</small></p> <p>4 ► SEISMIC</p> <p>► Cloud Physics</p> <p>► Sizers Portal page Sizers de uso frecuente: SimpliVity Sizer HPE Assesment Foundry</p> <p>► Reference Architectures Portfolio Arquitecturas de referencia para Microsoft, SAP HANA, Oracle, Citrix,...</p> <p>► Global TechHub Sección del TechHub en el portal.</p>	<p>5 ► One Config Advanced (OCA) Configurador Online de HPE.</p> <p>► Global TechHub</p> <p>6 ► Integrated Quoting 2.0 (Pricing) Sistema integrado para Quotes, Deal Registration y gestión de Oportunidades.</p> <p>► Price Communications Visor de Precios</p> <p>► HPE Renew – Inventory Today Sistemas reacondicionados a precios muy competitivos</p>	<p>7 ► Alinean ROI Analyst Incluye plantillas de análisis TCO/ROI para Synergy, 3PAR, StoreOnce, etc.</p> <p>8 ► Proposal Web</p> <p>► Products & Solutions Now Repositorio central de HPE de <i>Materiales de Marketing en inglés y en español</i> para cliente final y campañas</p> <p>Ver opciones de uso frecuente de SOLICITAR ASISTENCIA en la página siguiente</p>

RECUERDA: DESPUÉS DEL WEBFORUM DE HOY PUEDES ENVIARNOS TU FEEDBACK, Y TAMBIÉN TUS CONSULTAS Y PETICIONES

I. Feedback sobre el WebForum

II. Tus consultas y peticiones al Equipo del WebForum

III. "Feedback del mes"

3.I - TU FEEDBACK SOBRE EL WEBFORUM DE HOY *

¿Has encontrado el contenido del WebForum de este mes ÚTIL PARA TI?

1 - La mayor parte fué útil

2 - Solo una parte fué útil

3 - Nada o casi nada fué útil

NS/NC - No tengo opinión sobre esta pregunta

4. ¿Qué tema(s) te gustaría que tratemos en próximos WebForums?

5. TUS CONSULTAS Y PETICIONES

¿Tienes alguna consulta o petición que quieras hacer al equipo de HPE del Proposals Masters WebForum?

6.I - FEEDBACK DEL MES: Recibes semanalmente el "Boletín de Canal" de HPE *

Semanalmente el equipo de canal envía un comunicado en el que se informa de Novedades, Eventos y Formaciones, Promociones e Información sobre Herramientas de HPE

SI - Recibo semanalmente el Boletín de Canal de HPE

NO - No recibo el Boletín de Canal de HPE y me gustaría recibirlo

7.II- FEEDBACK DEL MES: En caso de SI recibir semanalmente el "Boletín de Canal" de HPE

Evalúa la utilidad del contenido recibido

☆☆☆☆☆

PRÓXIMO WEBFORUM 30 DE JUNIO

PRINCIPALES NOTICIAS DE DISCOVER



“ONE LAST SLIDE”

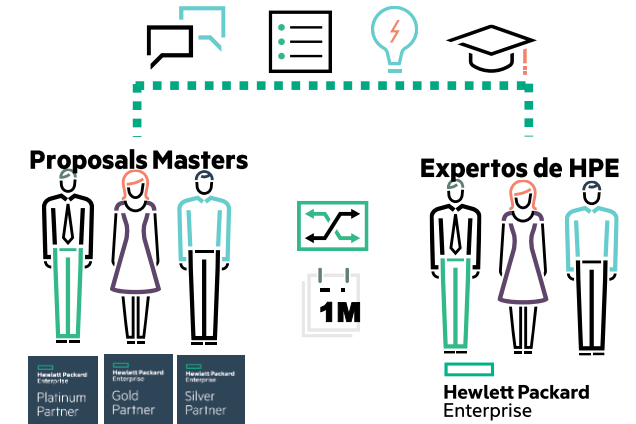
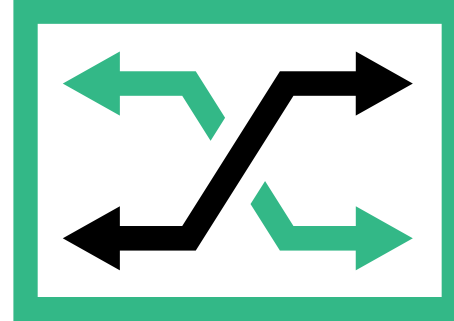
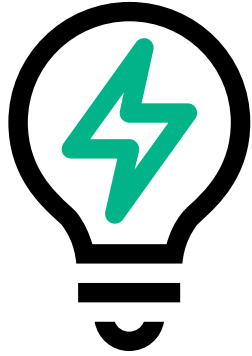

UN CONSEJO FINAL

Revisad vuestro status de cara al Readiness FY24

TUS FEEDBACKS Y TUS PETICIONES

Es fundamental para que este foro sea UTIL PARA TI.

Pincha en el enlace del correo que te enviaremos en breve. Toma menos de 2 minutos.

PRÓXIMOS WEBFORUMS

- **Junio: Viernes 30, 10 AM**

(NOTA: son las fechas previstas, pero puede haber cambios en caso de coincidencia con otros eventos de canal u otras causas de fuerza mayor)



**Thank
you**



**Hewlett Packard
Enterprise**

